

interweave@press

special issue

fall/winter 2005

knitscene™

44 cool
projects
for Making
Living
& Dreaming

please display until
February 27, 2006

www.knitscene.com

7.99 US/9.99 CAN

56 >



0 74820 87321 2





FILATURA DI CROSA

Italian elegance
Hi-fashion flair
Luxury fibers
Enduring looks



zara



127 print



bunny print



Tahki Yarns

Contemporary classics
Kicked-back casuals
All natural, all American
Totally timeless



alpaka soft



galaxy & sabrina



ritratto, miclo, ziggy, merino cable & sabrina



S.CHARLES COLLEZIONE

Cutting edge
Sophisticated chic
Totally textural
Made to mix and match

sign up for our new monthly newsletter
and get more free patterns at
www.tahkistacycharles.com

Tahki YARNS



fall/winter
2005 collection

free pattern
at www.tahkistacycharles.com

elliott, bunny print

TAHKI STACY CHARLES, INC.

70-30 80th Street, Building 36 Ridgewood, NY 11385
800.338.YARN

Classic Elite Yarns

LUXURY FIBER DIVISION

Blithe

Tryst

Indulge

Interlude

Posh

Sinful

Charmed

Allure

Sinful

Temptation

Blithe

Lavish

Posh Print

Charmed

Obsession

Playful Weekend

Embrace

Lavish

Posh

Temptation

Allure

THE PUREST AND
MOST LUXURIOUS
YARNS ON THE MARKET.
TO VIEW THESE CASHMERE,
SILK AND LUXURY BLEND YARNS,
VISIT OUR WEBSITE

WWW.CLASSICELITEYARNS.COM





knitstyle

- 10 **move over margaret thatcher**
Parliament goes glam!
- 20 **first frost**
COOL knits to keep you warm.
- 28 **keepsake or kitsch**
Retro yet Mod—projects to fit your eclectic personality.
- 42 **sunday a.m.**
For the man who has it all, including weekends OFF...
- 44 **be bohemian**
Knit some red hot folk.

When you see [on the web](#)

go to... www.knitscene.com

for complete instructions.
While you're there, look for
more photos of the projects in
this issue!

knitdepartments

- editorial** 4
- check it** 8
product reviews
- wear it** 26
ideas for sweater styling
- it's worth it** 34
fair isle knitting
- see it** 50
on the street: knits spotting
- the projects** 52
overview of instructions
- know it** 54
visual glossary of stitches

knitlife

- 18 **hook it UP!** A crocheted circle is just the beginning...
- 38 **loretta warner** Meet a knitwear designer who KNOWS the rules and KNOWS how to break them.

Welcome to the premier issue of Interweave Press *knitscene*—a magazine for knitters who can't get enough of knitting. You know what I mean. All those yarns—sumptuous, sparkly, and color rich—that beg to be swatched, all those projects—dainty, big-stitch, and whimsical—that clamor for a cast-on. *Knitscene* offers projects that are long on style, but not too long on technical know-how. If you follow trends, but go for the offbeat; if you love to knit, but aren't afraid to try a little crochet and embroidery, too; and if you like an occasional knitting challenge, but want a project that goes from start to finish in the same season, then open these pages—you're home. *Knitscene* brings you the stuff of knitters' dreams. Now wake up and get clicking!

Pam



interweave press **knitscene** a special issue

editorial

editor in chief Pam Allen
senior editor Ann Budd
contributing editor
Véronik Avery
technical editors
Lori Gayle, Karen Frisa
copy editor Stephen Beal
editorial assistant
Lisa Shroyer

creative services

designer Kit Kinseth
production director
Trish Faubion
production coordination
Mark Dobroth, Jason Reid,
Jeff Rowles
production editor
Nancy Arndt
photography
Carol Kaplan
(unless otherwise noted)
photostyling Mary Jane
Mucklestone
illustration Gayle Ford,
Ann Swanson

publishing

publisher Marilyn Murphy
display advertising manager
Tiffany Zerges
senior ad traffic manager
Teresa Warren
classified advertising
Corina McClanahan
promotions coordinator
Annie Hartman Bakken
web marketing manager
Bruce Hallmark
circulation director
Trish Carter
fulfillment manager
Jodi Smith
circulation manager
Barbara Naslund

projects and information are for inspiration and personal use only. *Knitscene* does not recommend, approve, or endorse any of the advertisers, products, services or views advertised in *knitscene*.

Nor does *knitscene* evaluate the advertisers' claims in any way. You should, therefore, use your own judgment in evaluating the advertisers, products, services, and views advertised in *knitscene*.

Interweave® Press *knitscene*™ is a special publication by Interweave Press LLC, 201 E. Fourth St., Loveland, CO 80537-5655. (970) 669-7672. All contents of this issue of *knitscene* are © 2005 by Interweave Press LLC. All rights reserved. Projects and information are for inspiration and personal use only. Reproduction in whole or in part is prohibited, except by permission of the publisher.

visit the *knitscene* website at www.knitscene.com

for advertising information, call Tiffany Zerges at (877) 669-7455, e-mail tiffanyb@interweave.com or visit www.interweave.com. For sales information, call (800) 272-2193 or e-mail sales@interweave.com.

for retail sales of magazines and Interweave Press books contact Kerry Flint (800) 272-2193 ext. 673 or kerryf@interweave.com.

for editorial inquiries, call (800) 272-2193, e-mail knitscene@interweave.com, or write to 201 E. Fourth Street, Loveland, CO 80537-5655.

Interweave Press magazines *Beadwork*, *Fiberarts*, *Handwoven*, *Interweave Knits*, *PieceWork*, *Spin•Off*

Interweave Press LLC
201 East Fourth Street
Loveland, Colorado 80537
(970) 669-7672

An Aspire Media company 

Rebecca

baby+kids

"REALLY
BIG FASHION!"



For a Retailer near you email us at: rebecca@muenchyarns.com
The new Rebecca baby+kids, Knitwear designs easier than ever!

FREE projects • FRESH ideas • techniques • HOW-TO • and MUCH MORE



striped scarf



ruffle scarf



crochet bracelet

Not just a magazine...
www.knitscene.com

Want to see more images? of a knitscene project go to...

www.knitscene.com

Can't find the yarn? Visit an independent yarn shop near you. Complete shop listing on...

www.knitscene.com

Still not enough? More knitting, more projects, more news, more, more...

www.interweaveknits.com

the web connection to advertise here call Corina McClanahan at (877) 613-4621

books

Interweave Knits
www.interweave.com/knit
(800) 272-2193

buttons

Creative Impressions in Clay
www.claybuttons.com
(513) 755-2155
Fax (513) 755-2225

magazines

KnitNet
www.knitnet.com
KnitNet Magazine

mail order

Knit and Stitch = Bliss
www.knitandstitch.com
(866) 5NEEDLE
West Valley Alpacas
www.westvalleyalpacas.com
(530) 662-8630

new shop

Stitch Therapy
A Fine Yarn Shop
www.stitchtherapy.parkslope.com
(718) 398-2020

patterns

Dovetail Designs
Knitting and Crochet Patterns
www.dovetaildesigns.com

Talitha Cumi Co.

www.cumicrochet.com
(509) 779-0221

supplies

Brittany Company
www.brittanyneedles.com

web sites to visit

Dream Weaver Yarns LLC
www.dreamweaveryarns.com
info@dreamweaveryarns.com

Halcyon Yarn
www.halcyonyarn.com
(800) 341-0282

JConklinDesigns
www.rjconklin.com
jconklin@rjconklin.com

Knit Pixie
www.knitpixie.com
info@knitpixie.com

Spirit Work knitting & designs, Inc.
www.spiritworkknit.com
(585) 544-9107

The Knitting Room
www.knitroom.com
(877) 264-7229

Woodland Woolworks
www.woolworks.com
(800) 547-3725

yarns

Genesis Alpacas
www.genesisalpacas.com
(360) 659-1990

Louet Sales
www.louet.com
(613) 925-4502

Muench Yarns
www.muenchyarns.com
info@muenchyarns.com

Royal Yarns
www.royalyarns.com
(202) 215-2300

Russi Sales
www.russisales.com
(800) 950-1078

Skacel Collection, Inc.
www.skacelknitting.com
(800) 255-1278

Tahki/Stacy Charles, Inc.
www.tahkistacycharles.com
(800) 338-YARN

Unique Kolours
www.uniquekolours.com
(800) 25-2DYE4

Wool 2 Dye 4
www.wool2dye4.com



S. CHARLES COLLEZIONE



cutting edge
sophisticated chic
totally textural
made to mix and match

TAHKI STACY CHARLES, INC.

70-30 80th Street, Building 36 Ridgewood, NY 11385

800.338.YARN

www.tahkistacycharles.com

To order our new booklet, visit our web site.

Be Sweet yarn

When you buy Be Sweet yarn, good karma will come to you. Not only is the yarn a boon to your stash craving, its purchase will benefit a group of Xosa women who live in rural South Africa. Be Sweet founder, Nadine Curtis, reports that the business employs women in this depressed area and donates a part of Be Sweet proceeds to the local school. The women spin and dye 100 percent baby mohair in six different textures and a large array of delicious colors—check them out at www.besweetproducts.com.



Knit Couture project planner

This beautiful binder is not a photo album—it's a project planner from Knit Couture. The handy book stores all your project notes, photos, patterns, and the stats of your yarn stash; it can be customized by adding your own pages. The plastic slipcovers can be removed so you can take along pages when you travel. Get your knitting life organized, and at the same time accessorize your coffee table in style. Makes a great gift! www.knitcouture.com.

Umahlinda needle holder

Go wild with Umahlinda's exotic needle holders. The animal print Flat Foldie Needle Holder and Taz Needle Holder offer convenient and stylish ways to stash crochet hooks and knitting needles of all shapes and sizes. The Taz Holder is a zippered cylinder; the Flat Foldie is a quilted, cushioned folio with pockets for all your tools. Umahlinda has a great collection of craft accessories available online at www.umahlinda.com.



Clover pom-pom maker

The Clover pom-pom maker is essential for the creative knitter. This clever plastic device makes satisfyingly plump, well-rounded pom-poms with little effort. By winding yarn around the arched pieces, fitting them together, then cutting, you have a perfect pom-pom in a matter of minutes. The set contains four makers in different sizes; you can make pom-poms from a dainty 1" to a 3" baseball size. Look for the Clover pom-pom maker at your local yarn shop, then grab some scrap yarn and start winding!

GoKnit Pouch

The GoKnit Pouch encourages you to knit on the go. The small bag can be worn on the waist or wrist, and makes a perfect accessory for any knitter. The 8½" by 8", rip-stop nylon pouch closes with a drawstring, has a handy snap loop that attaches to a belt, features an internal yarn guide, and comes in a range of colors from bright green to fuchsia. Choose one of these on-the-go knitting bags to liven up your wait at the post office. Find out more at www.knowknits.com.



Classic Elite Yarns

Fall '05 knitting can be fast and fun.

Shown here in **MarL La**, 100% marled wool, 2 sts/in on #17 needles, are a simple cropped cardigan, with "a-la-mode" embellishments; and a child's hooded vest, a perfect project for the new knitter.

These are among many, quick-and-easy garments featured in our new "**great BIG knits**" Booklet.

The hat, scarf and wristlets are knit in 'companion' yarns, **Princess** 5 sts/in and **Duchess** 3½ sts/in – cashmere, angora, extra-fine merino wool – available in identical twenty-one colors. These yarns are perfect for combining colors to knit small, portable fun-to-knit projects.

Princess and **Duchess** patterns are found in the "**First Edition**" Booklet.

To mail-order these Booklets, send \$12.95 each to:

Classic Elite Yarns • Dept. KSF05 • 122 Western Avenue • Lowell, MA 01851



Princess & Duchess
"First Edition"
Booklet



Visit our website,
www.classiceliteyarns.com
for images of all garments in all Booklets,
all yarns in all colors,
and to find a retailer in your area.



MarL La
"great BIG knits"
Booklet



move over
margaretthatcher

Iron Lady style has trickled down—stately ruffles, notched collars, and tidy buttons. . .knit up these hallmarks of grown-up dressing.



02

on the web
knitscene.com

01 Flamboyant cuffs in a nubby Monet-colored yarn are the perfect foil for the uncluttered lines of this belted jacket. No-roll seed stitch, knitted in as you go, borders the edges.

02 A staple of sensible dressing, the traditional tweedy vest goes glam when knitted in a royal purple and draped with strands of regal pearls.



Ruffles and sparkles fit for a Lord

03 The Chanel jacket is the emblem of urbane, no-nonsense style, even when it's tricked out with a sprinkling of mother-of-pearl buttons and a lustery knitted trim.

04 Free markets, free minds, free ruffles! Worked in a single airy strand of silky kid mohair, these ruffles spill dangerously from this fitted wrap cardigan. Smooth raglan shaping makes for a flawless fit at the armholes.





05

on the web
knitscene.com

Pinks fit for Parliament



05 A spicy mix of pinks warms up a clipped double-breasted jacket—a fifties remake with a nipped-in waist and perfect notched collar. The jacket works up quickly when you combine a strand of variegated mohair with two strands of cushy alpaca.

06 Our version of coat and tails—knot them or let them hang, either way, this simple cravat is a stand-up accessory.

07 A modern version of a lady's accessory, these vibrant gloves with a piquant cuff bring home your point. Number 10 Downing is dowdy no more.



Accessories rule!

08 Satiny slubs punctuate a simple rib pattern in this after-hours clutch. Add crocheted pins (page 18) or leave it unadorned; either way, your bag won't go unnoticed.

09 Clever folding turns a knitted rectangle into a quirky topper. Team it with a fitted retro jacket and for a little whimsy, add some oversize bicolored pom-poms on a twisted cord.



09



Hook it UP!

crochet a circle and see where it takes you...



here's how—

make a foundation ring—

1 Start by making a short chain: Make a slip knot on the hook and chain 4 (ch 4). (1)

2 Join the chain into a circle with a slip st: Insert the hook into the first chain made (actually the slip knot; see arrow in figure 1)—you will have 2 stitches on the hook—then yarn over and pull a loop through both stitches. (2)

3 Gently pull on the yarn tail to tighten up the initial slip knot, ch1, and get ready to work into the ring you've just made. (2)

work into the ring—

4 Work 5 single crochet (sc) into the ring—because the ch 1 in Step 3 counts as 1 sc, there will be 6 stitches total (including the stitch on the hook). (3)

5 Join the first and last stitches of the round by working a slip stitch (sl st) in the first stitch made—6 stitches around the outside of the ring. Then get ready to work another round into the sc stitches just made. (4)

next round—work 2 sc in each stitch

6 Ch 1 (this counts as 1 sc), work 1 sc into the same space as the slip stitch you've just made. Then work 2 sc into each of the stitches in the ring (5)—you'll have 12 stitches. Join first and last stitches with a slip stitch (shown by the arrow) as you did before.

next round—work 2 sc in every other stitch

7 Ch 1 (counts as 1 sc), work 1 sc into the same space as the slip stitch in Step 6, then work 1 sc in the next stitch, *2 sc in next stitch, 1 sc in next stitch; rep from * to end of round—you'll have 18 stitches. Join with a slip stitch.

next round—work 2 sc in every third stitch

8 Ch 1 (counts as 1 sc), work 1 sc into the same space as the slip stitch, then work 1 sc in the next 2 stitches, *2 sc in next stitch, 1 sc in next 2 stitches; rep from * to end of round.

To make a circle, continue working around as above. Begin each round with a single chain stitch, and add one more sc between the stitches in which you work 2 sc. As your circle gets larger, work the 2 sc-in-one-stitch in different places in the round, otherwise, your circle will develop points on top of the stacked increases.

Get creative by changing colors, working half-double crochet (ch-2 at the beginning of each round), or adding fancy stitches as you go around. ☐

learn more about crochet motifs!

Two books we like are: *Crochet Basics* by Jan Eaton (Barron's, 2004) and *How to Crochet* by Pauline Turner (Collins & Brown, 2001; distributed by Sterling Publishing Co.).

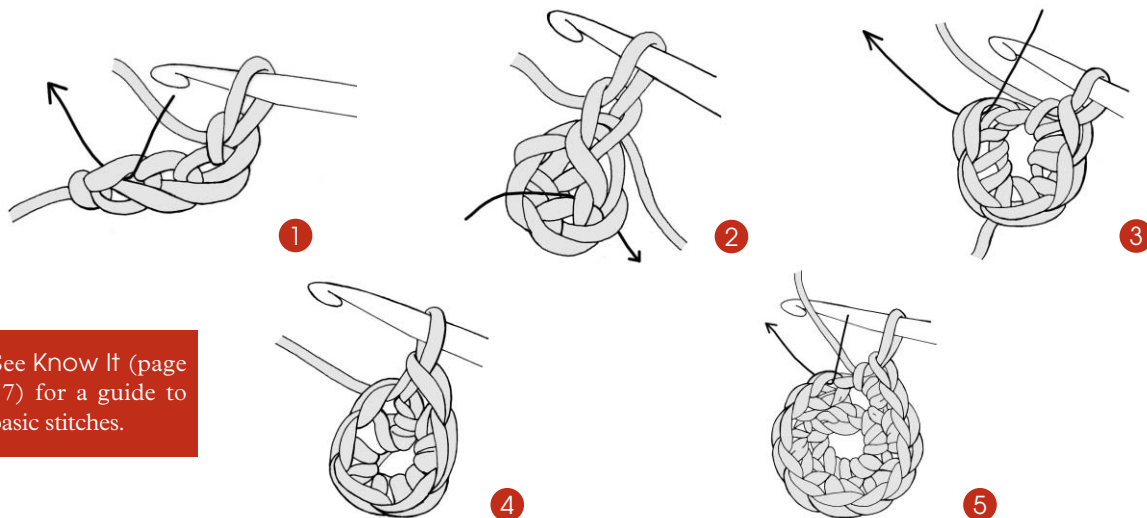

See Know It (page 57) for a guide to basic stitches.

on the web specific instructions for the projects on page 18 are available at www.knitscene.com.

firstfrost

Crystals form, dreamlike,
on the grass...

10

Greet the dawn in a Nordic sweater in wintery blues.

10 A Viking-size XOX motif circles this soft raglan pullover, perfect for fending off the chill of early morning.

11 This cropped cardi is sweet and brief, with no closures to interrupt the gentle roll of its graceful collar.



Knit another layer and step out into the sparkling world.

12 Top your jeans with this floaty tunic, crocheted in soft, shimmery mohair.

13 Simple and unadorned—and 100 percent cashmere—this pullover is made for wintry comfort.





Savor colors from the winter woods, the velvet mosses, the shaggy evergreens.

14 Make a long, roomy sweater coat whose decorative crocheted edging recalls the rustling of forest leaves and ferns.

15–16 Worked in a marled yarn, this little skirt uses decorative decreases for added texture. Crochet the border pattern by itself and wear it as a scarflet to take off the chill.





15

16

wearit

sweaterstyle

by Véronik Avery



A luxurious silk-and-cashmere cardigan looks playful over a graphic tee, but paired with a pleated printed skirt, it's a sophisticated cover-up.

#11, page 21



Look for: a pleated skirt in a fun print and a retro blouse. Lace tights—all the rage this fall—would add a bit of offhand sophistication.



Wear a strapless vest under a jacket for warmth and a flash of color, or let it take center stage over your favorite denim skirt.

#25, page 34

Look for: a shaped tweed jacket, flared pants, and pumps with peek-a-boo toes. A leather satchel in a bright neutral completes the ensemble.

Look for: a graffiti tee, cropped cargos, and fun flats. Add a handknitted hat in self-stripping yarn, but be sure to make it a tad too long for that critical bit of insouciance.



Look for: an antiqued denim skirt with a slight A-line, a fun tote, and low-heeled boots.



Look for: a structured skirt and form fitting t-shirt with lingerie details. Pumps with a slightly exaggerated sole keep the look feminine and modern.

Balance the look of big knits by layering them over a trim silhouette. Let them hang open in a casual way.

#34, page 44

#41, page 48



Look for: boot cut cords, a turtleneck in a soft hue, and a hand-knit beret like the one you see on page 36.

keepsake or kitsch

knit a flea market find that you won't have to scrounge for...

17 Soft and cable-y, wear these fingerless mitts when cruising yard sales.

18 Crocheted moccasins add a little funk when you slip them on with an antique petticoat. (See the kid and guy versions on pages 32 and 43.)

19 A vintage lace pattern forms a scalloped border on this swingy cashmere-blend cardigan.





20 A kicky skirt in silky nubbed yarn is worked sideways in one piece. It goes around from center back to center back and is shaped with short rows at sides and hem.

browse your needles and start knitting...

21 A diminutive crocheted collar and over-size buttons add vintage flavor to in this silk-tweed cardigan. The flecked yarn has a handspun look, and the I-cord drawstring cinches in at just the right spot.

22 An oh-so '50s French Blue twinset. The collared shrug is worked in a simple variation of a classic rib stitch and the sleek shell features a wide, squared neckline.





22

on the web
knitscene.com



bag a purly treasure

23 Crocheted flowers in hot-house colors bloom on a drapy afghan. Toss it on an overstuffed armchair or fold it at the foot of your bed.

24 Little posies peek from the heels of this dainty pair of crocheted kid's slippers.

25 Knitted in a richly textured yarn, this tidy tam for the stylish coed is thoroughly modern—in a retro kind of way.





26

26 A black velvet ribbon adds starlet glamour to a cherry red cardigan with narrow puffed sleeves. Don't forget the cherry red lipstick...



27

fair isle knitting

it's easier than you think!

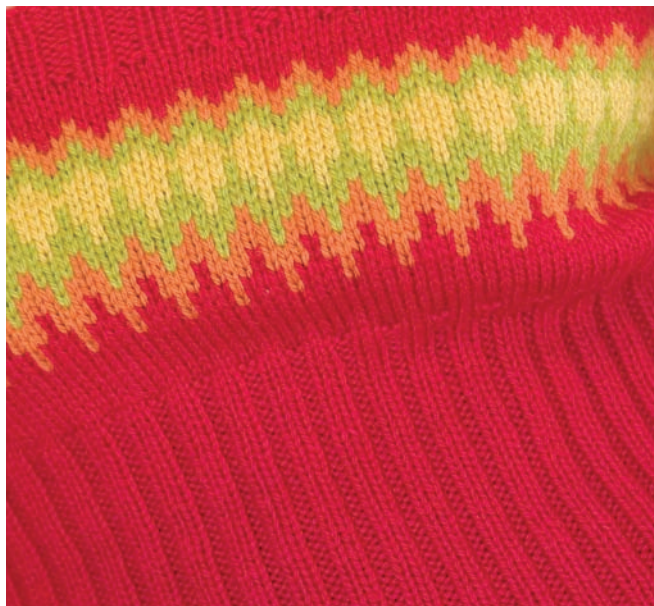

Knitting in Fair Isle involves working two or more colors on one row of a pattern. It isn't much more complicated than knitting or purling in one color, but it can produce some really stellar fabrics. Basically, you'll work a few stitches in one color, then the next few in a second color—both balls of yarn always staying attached to the work. The color that isn't being worked is carried across the back of the knitting, making a snug loop, a "float," before being worked again. If you look at the reverse side of a sweater worked in Fair Isle, you'll see the floats; they make a pattern of their own. They also add thickness and warmth to a garment, as they essentially add an inside lining to the sweater. Most Fair Isle patterns only call for two colors in any given row—more than two does make knitting more complicated.

To make a practice swatch, gather four colors of yarn (in this case, red, orange, green, and gold). With red, cast on 24 stitches and work a few plain rows. Then with the right side of the knitting facing you, follow the instructions and the Fair Isle chart at right.

on right-side (knit) rows

1 Following chart for Row 1, knit the first two stitches with red. Drop red to the back (wrong-side) of the work and tie on the second color, orange (1).

2 Knit the next stitch (as shown on the chart) with orange, then drop orange to the back of the work (2).

3 Pick up red from where it's hanging at the back of the work, bring it over the strand of orange just dropped, leaving enough slack for the yarn to span the orange stitch (3). This will be your float. You want to pull it snugly enough that it won't snag on things, but loose enough that it doesn't pull on the fabric of the knitting. Knit the next stitch with red. This brings you to the end of the pattern repeat on the chart.

4 Work two more stitches of red (the first two stitches of the second pattern repeat). Pick up orange from the back of the work and bring it under the strand of red just dropped. Make a nice float (with orange) across the back of the last three red stitches, and knit the next stitch in orange (4).

Continue repeating Steps 3 and 4—working the number of stitches shown on the chart for each color—until you get to the end of your first row. Turn the work around in preparation for the second row, which will be a wrong-side (purl) row.

on wrong-side (purl) rows

Work wrong-side rows just like right-side rows, but purl the stitches instead of knitting them, and drop the yarns to the front of the work (facing you) instead of to the back. Your wrong-side rows should correspond with even-numbered rows on the chart. Most Fair Isle patterns are worked in the round, so you won't have to work wrong-side rows; but for the sake of a small swatch it's easiest to go back and forth.

Continue repeating right-side and wrong-side rows to the end of the chart, 19 rows in all. You will tie on green and gold just as you tied on orange. When you get to areas where a color has not been used for several rows, it's best to break it off, then tie it on again when you need it. You don't want floats going *up* the back of your swatch.

finish it

When you've finished the piece, untie the knots where you joined new colors. Thread the yarn ends on a tapestry needle and weave them into the back of the work, keeping to the same colors as much as you can. □

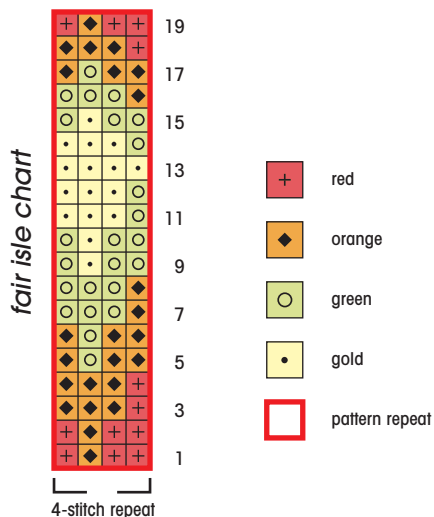
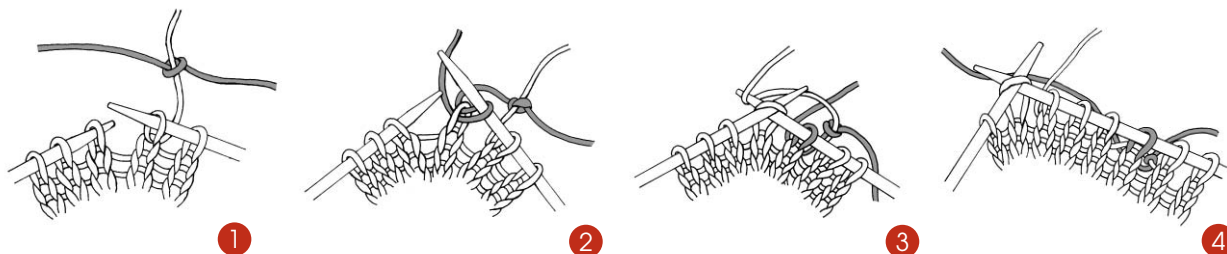

tips

make sure your floats aren't carried too tightly across the wrong side of the work, or the fabric will pucker. An easy trick is to spread out the stitches on the right needle every time you change colors. This will give the float the same horizontal stretch as the stitches on the needles.

to prevent tangling of the two strands of yarn, always pick up the first color *over* the second, and pick up the second color from *under* the first. Sometimes keeping one ball on your right side and one between your legs helps keep them apart.

to read the chart— work from bottom to top. Follow the boxes right to left on right-side rows and left to right on wrong-side rows.



Coming soon



designed by **Rebecca**

CASHMERE

Still fancy even more fashion trends?
The latest trends – we have them all!



Rebecca *Update*

New from Fall 2005!

Both instore and on the internet



28

on the web

knitscene.com

An asymmetric opening adds interest to a simple plush cardigan.

loretta warner— imagination on the loose

by Nancy Denkin and Kathryn Martin



above: photos of Loretta Warner by Kathryn Martin

Loretta Warner lives and works in her upstairs second-story studio, part of a charming older building in a neighborhood of interesting shops and markets in Berkeley, California. She shares a common sun-filled veranda with five or six offices, and she is known to fellow tenants as Queen of the Corner. “When they leave their offices, the lawyers see my yarns in the sun, and they’re amazed at how beautiful they are.”

Warner shares her living/working space with neatly coned yarns in a wonderful variety of colors and textures; a drafting table provides the center for her creations. Her sketches, yarn samples, and buttons—the sources of her inspiration—are neatly arranged in binders. Knitting machines are steps away. Here her garments take shape, each carefully measured and checked many times in front of an ornately framed mirror. A dressmaker’s dummy draped with pieces of knitted fabric stands nearby.

Warner grew up in San Jose, California, where the seeds of her interest in fashion design were planted early. As one of eight

children, she learned to knit and sew from necessity, and her first project was a pair of slippers worked in rug yarn. She remembers an early lesson in the requirements of knitwear design: “One Christmas when I was a little girl, I knitted slippers for all my brothers and sisters. The soles of the slippers quickly wore through, and I realized my mistake. I should have put leather on the bottoms.”

In a high school sewing class, Warner made herself a coat using a Vogue designer pattern as the starting point for her own experimentation. She also used a Vogue sewing pattern as a guide for her first long-sleeve sweater, a cardigan with a big collar. “My Purple Bomb was completed when our astronauts were walking on the moon.”

Her pleasure in working with color and in creating unique garments steered her to design school. She received a BFA in fashion design from Lone Mountain University in San Francisco in 1977. “As a designer, you need your own fabric,” says Warner, so she started weaving her own fabrics. To her handwoven garments, she added knitted cuffs, collars, and borders. Her first orders came from Nordstrom’s, but making fabric on a loom was such slow work that she couldn’t keep up with demand. Nor could she create fabric with the kinds of patterns



29

on the web

knitscene.com

Sparkly buttons peek out at random on a glittery, fluffy shawl.



30

on the web

knitscene.com

A mix of variegated mohair, handspun wool, and silky ribbon makes a dramatic shrug.

she was looking for—paisleys, dots, and animals. She found that she could work faster and more creatively on a knitting machine. Now Warner creates a line of knitwear that she supplements with sewn garments and knitted silk camisoles.

Warner's approach to design is intuitive. Holding a ball of yarn in her hands, she says, "Listen to the yarn; let it tell you what it wants to be." Nonetheless, she also feels it is important to learn to do things by the book, "Learn classic tailoring first, then take it apart. Learn the rules, then break them." She gets her ideas from many sources: fine art, photography, fashion design—she likes Galliano, Marc Jacobs, and Yves St. Laurent—and from her favorite books, like *The Quilts of Gee's Bend* and *The Mode of Costume*.

Warner believes that all women have beautiful bodies, bodies that need to be shown to their best advantage. Her stunning one-of-a-kind garments exemplify this philosophy—an airy mohair jacket is sensually accented with a brilliant bias-cut organdy lining that moves gently and comfortably within the body of the jacket.

While Warner loves to work with bold colors and patterns, she's attentive to small details as well. When she was young, she never wasted an ounce of fabric in her sewing projects. Even now, remnants of yarn and fabric find their way into many of her garments—they've become a kind of signature. Unused pieces of yarn enclosed in delicate netting become beautiful cuffs that almost serve as bracelets for drapery chenille sweaters.

This fall, Warner's business will take a new direction as she prepares to open her studio for classes, knitting workshops, and retail yarn sales. She also plans to emphasize her collection of pillows and throws for the home.

Although it isn't part of her business, Warner hasn't given up handknitting. At the moment, she is working with materials gleaned from a basket of leftovers—bright rayon ribbons and the cut-off-and-saved selvages from oriental brocaded fabrics used in one of her collections. Worked on large needles, these long skinny scraps are knitting up into a glorious hand-bag. In Warner's studio, creative potential is ready and waiting everywhere she looks. [O]

To see more of Loretta's work, visit www.lorettawarner.com.



ZARA

FILATURA DI CROSA



classic merino wool
over 80 colors
24 timeless designs

TAHKI STACY CHARLES, INC.
70-30 80th Street, Building 36 Ridgewood, NY 11385
800.338.YARN
www.tahkistacycharles.com
To order our new booklet, visit our web site.

A man with short dark hair and a slight smile is looking off to the side. He is wearing a dark-colored sweater with thin, multi-colored horizontal stripes in shades of orange, blue, green, and purple. The sweater has a crew neck and ribbed cuffs. In the background, a woman is visible from the back, wearing a light-colored top, standing near a window. The lighting is soft and natural, suggesting an indoor setting.

sunday a.m.
got up late...

31

put on the coffee, headed to the corner for bagels and the *Times*...



31 Relaxed and handsome, and knitted from the neck down, here's a simple sweater for an uncluttered morning.

32 Narrow stripes and bold colors in silky merino make a scarf for the Great Indoors.

33 Strong colors and simple crochet combine in a stylin' pair of slippers.



34

35

bebohemian

funky and festive, knits for the free-spirit



34 Unleash your inner hippie chick with a big-stitch cardigan that likes to hang out where you do. Easy knitting on big needles leaves lots of time for flying kites.

35 Tie one on—a glittery crocheted belt threaded with ribbon adds sparkle to whatever you're wearing.

36 Earth tones sparked with a bit of Romanian red warm up a roomy sweater. A simple slip-stitch pattern makes for easy two-color knitting.

37 Warm earflap hats never lose their cool. These take you from the woods to the slopes.

be sassy

38 Knit a pair of carefree chunky red socks for the last days of autumn.

39 Stow your stash in a felted hobo bag embellished with cross-stitches and pom-poms.

40 The seam's the thing—make a sweater wrong side out and embroider the edges in bright crayon colors.



40



be sexy

41 Don crocheted jewels and a hat to match.

42 Slide on a swiny cardigan over a little black dress. In cream and earth tones, this wooly yarn is as soft and silky as dandelion fluff.

43 Wrap your neck in Willy Wonka stripes trimmed with pom-poms.

44 Tap your imagination and creative genius! Make a set of funky dolls; there's no limit to where these little folk will take you.





43



44



see it
on the street...

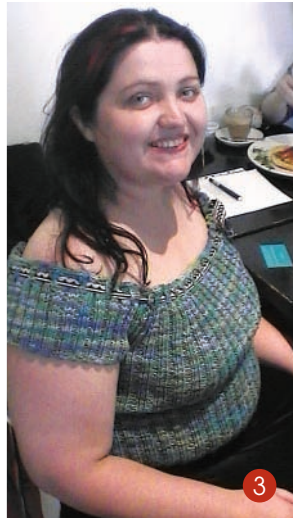

knitspotting

From NYC to Sydney, Australia, knitters take their knits to the street. Wacky and wild or cool and easy, we'd love to see the knits you're wearing. E-mail us a photo (JPEG or TIF formats) to knitscene@interweave.com—we'll post your design on our website, www.knitscene.com.

Your on-the-street photographers are Alison Brookbanks in Australia and Carl Luna in NYC.

1, 3, 6 Alison Brookbanks, Sydney and Melbourne, Australia, 2005.
2, 4, 5, 7, 8, 9 Carl Luna, NYC, 2005.

Visit www.knitscene.com for the scoop on these knits.



Colinette
YARNS
www.colinette.com

JELLY
Introducing
The Amazing
ALL STARS



* POPSTAR

TOP DESIGNS FOR KNITTING'S LITTLE HEROES



Colinette
YARNS

*Crocheting
to dye for!*

"Flapjack Throw" crocheted in
Colinette "Prism" from the book
Toast & Marmalade.

Inspirational Fibers for Passionate Knitters!

For your nearest Colinette retailer in the United States,
please call Unique Kolours at (800)-25-2DYE4 or visit us online.

www.uniquekolours.com

level of difficulty:

- ○ ○ ○ I've learned the basic stitches
- ● ○ ○ I'm ready to move past scarves
- ● ● ○ I'm feeling pretty confident
- ● ● ● I'm ready for a challenge

size it • This is where we tell you the circumference of the finished sweater. If you don't know what size to make, measure your favorite sweater and go from there.

gather it • Here's what you need to make the sweater: the yarn, needles, and any tools or other gizmos. Keep in mind that the needle size listed may not be the size YOU need to get the correct gauge (see below).

gauge it • Don't be tempted to skip this part. If you want your project to fit, your stitches and rows have to match these numbers. Don't worry if you need to use different needles than those given above.

note it • Here's where you'll find some key points about how the project is made, including special stitches and abbreviations.

learn it • lingo

work even, work even in patt • continue what you are doing without increasing or decreasing. You'll often find this phrase right after you've worked the armhole shaping (bind off and decreases).

work stitches as they appear • this means that if the next stitch looks like a knit stitch, you knit it, and if it looks like a purl stitch, you purl it.

*...; rep from * • when you see this combination of asterisk and semicolon, it's shorthand for telling you to repeat something, e.g. “*k2, p2; rep from * 4 times” tells you to work the k2, p2 sequence a total of 5 times.

end with a WS row • the last row you work should be a wrong-side row, the next row will be a right-side row.

end with a RS • the last row you work should be a right-side row. The next row will be a wrong-side row.

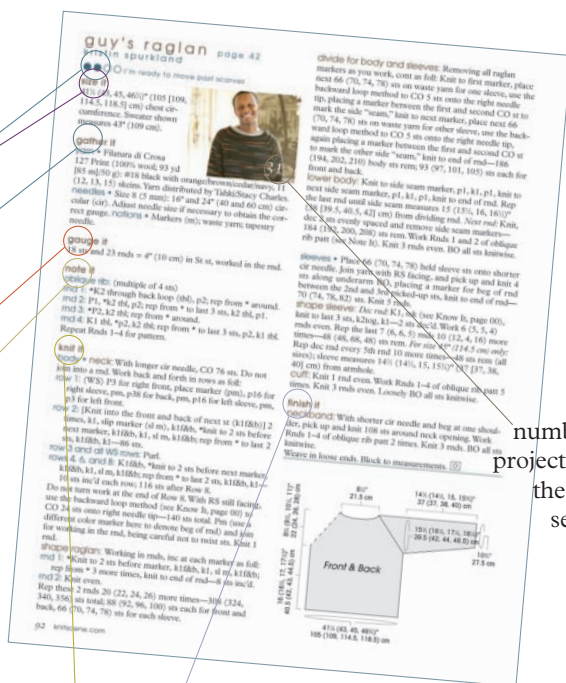

knit it • Finally, the step-by-step instructions, i.e., stitch by stitch and row by row, for your project. Most sweaters are worked in this order: back, front(s), sleeves, and finishing. See the sweater map on page 53 to see how the pieces fit together and the most common abbreviations used in sweater patterns. Learn the lingo below. See pages 55–57 to learn the most common techniques used by knitters.

finish it • Now turn your pieces into something you can wear or into a finished project.

with RS facing • as you hold your knitting ready to knit, you'll be looking at what will be the right side of your sweater.

place marker • markers are used to help you keep track of groups of stitches. To place a marker, put a purchased marker (a little ring) or tie a piece of yarn on your needle, work the next stitch, and carry on. Whenever you come to the ring, simply slip it from the left needle to the right needle.

bind off in patt • as you bind off stitches, knit the knit stitches and purl the purl ones.

every other row • sometimes your pattern will tell you to work an increase or decrease every so often. Most patterns ask you to work decreases or increases on right-side rows. Every other row means working the increases or decreases on every right-side row; every fourth row means you'll work the increase or decrease on the first row, work 3 rows even, then on the next row (right side), work the increase or decrease again.

number of project from the front section

learnit • abbreviations

beg	beginning; begin; begins
bet	between
BO	bind off
cm	centimeter(s)
CO	cast on
CC	contrast color
cont	continue(s); continuing
dec	decrease(s); decreasing
dpn	double-pointed needle(s)
fol	following; follows
g	gram(s)
inc	increase(s); increasing
k	knit
k1f&b	knit into front and back of same st
k2tog	knit two stitches together
kwise	knitwise
m	marker(s)
MC	main color
mm	millimeter(s)
M1	make one (increase)
p	purl
p1f&b	purl into front and back of same st
p2tog	purl two stitches together
patt(s)	pattern(s)
pm	place marker
pssso	pass slipped stitch over
p2sso	pass two slipped stitches over
pwise	purlwise
rem	remain(s); remaining
rep	repeat; repeating
rev St st	reverse stockinette stitch
rnd(s)	round(s)
RS	right side
rev sc	reverse single crochet
sc	single crochet
sl	slip
sl st	slip stitch (sl 1 st pwise unless otherwise indicated)
sp	space
ssk	slip 1 kwise, slip 1 kwise, k2 sl sts tog tbl (decrease)
ssp	slip 1 kwise, slip 1 kwise, p2 sl sts tog tbl (decrease)
st(s)	stitch(es)
St st	stockinette stitch
tbl	through back loop
tog	together
WS	wrong side
wyb	with yarn in back
wyf	with yarn in front
yo	yarn over
*	repeat starting point (i.e., repeat from *)
()	alternate measurements and/or instructions
[]	instructions that are to be worked as a group a specified number of times

learnit • sweater map

1 start here, make back



1 cast on and work rib or other edging

2 shape armholes

3 shape neck and shoulders

2 make front



1 make the front the same as the back to the beginning of neck shaping

2 bind off center stitches for neck

3 shape shoulders

3 make sleeves



1 cast on for rib and make increases along side edges

2 shape cap

4 block



pin pieces out and hold a steam iron over them without touching the surface

5 sew pieces together

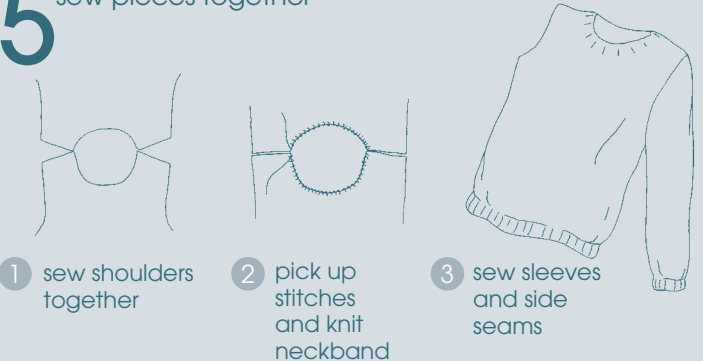

1 sew shoulders together

2 pick up stitches and knit neckband

3 sew sleeves and side seams

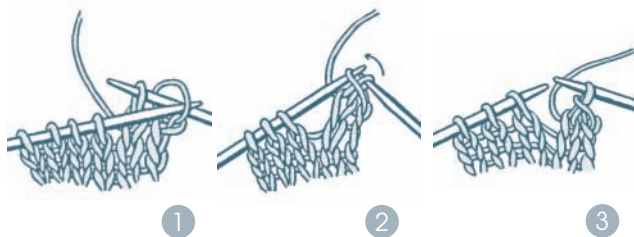

bind-offs

standard bind-off

Slip one stitch, *knit one stitch, insert left needle tip into first stitch on right needle (1), pass this stitch over the second stitch (2), and off the needle—one stitch remains on right needle and one stitch has been bound off (3). Repeat from *.

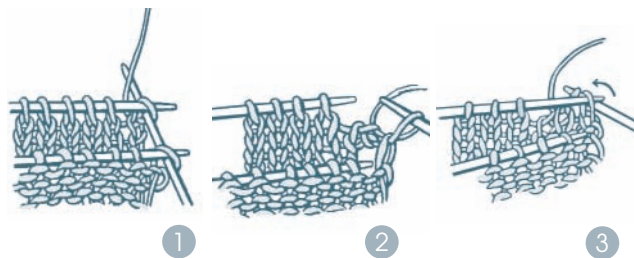

three-needle bind-off

Place stitches to be joined onto two separate needles. Hold the needles so that right sides of knitting face together. *Insert a third needle into first stitch on each of the other two needles (1) and knit them together as one stitch (2), knit the next stitch on each needle together in the same way, then pass the first stitch over the second (3). Repeat from * until one stitch remains on third needle. Cut yarn and pull tail through last stitch.

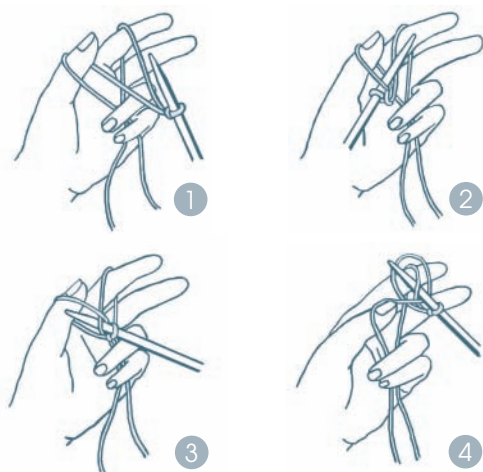

cast-ons

continental (long-tail) cast-on

Leaving a long tail (about 1/2" to 1" [1.3 to 2.5 cm] for each stitch to be cast on), make a slipknot and place on right needle. Place thumb and index finger between yarn ends so that the working yarn is around your index finger and the tail end is around your thumb. Secure the ends with your other fingers and hold palm upward, making a V of yarn (1). *Bring needle up through loop on thumb (2), grab first strand around index finger with needle, and go back down through loop on thumb (3), drop loop off thumb and, placing thumb back in V configuration, tighten resulting stitch on needle (4). Repeat from * for desired number of stitches.



backward loop cast-on

*Loop working yarn and place on needle backward so that it doesn't unwind. Repeat from * for desired number of stitches.



decreases

k2tog

Knit two stitches together as if they were a single stitch—two stitches are reduced to one.

ssk

Slip two stitches individually knitwise (1). Insert tip of left needle into front of these two slipped stitches and use right needle to knit them together through their back loops (2).
(Some knitters like to slip the second stitch purlwise to make a more prominent decrease line.)

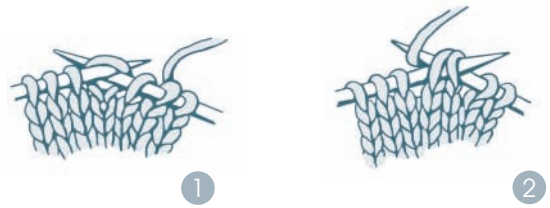

ssp

Holding yarn in front, slip two stitches knitwise one at a time onto right needle (1). Return the two stitches to the left needle and purl them together through their back loops (2).

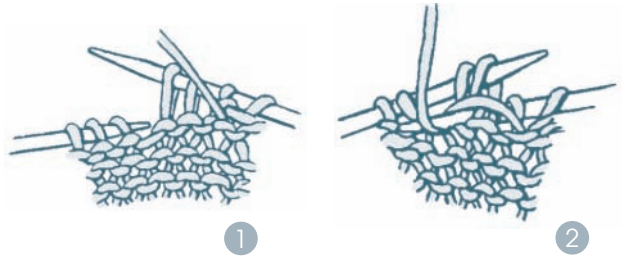

increases

raised increase (M1)

Unless otherwise indicated, work this increase as M1L.

Left Slant (M1L): With left needle tip, lift strand between needles from front to back (1). Knit the lifted loop through the back to twist the stitch (2).

Right Slant (M1R): With left needle tip, lift strand between needles from back to front (3). Knit the lifted loop through the front to twist the stitch (4).

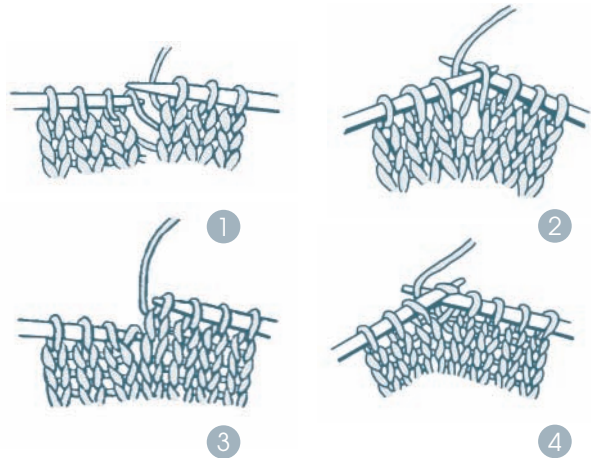

bar increase (k1f&b)

Knit into a stitch and leave it on the needle (1), then knit through the back loop of the same stitch (2).

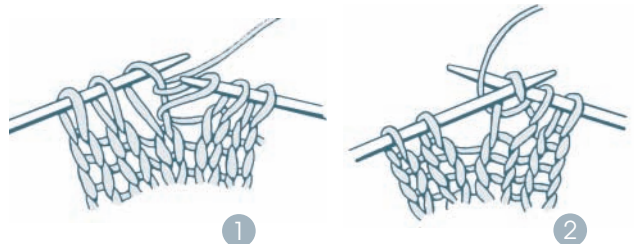

invisible vertical seam

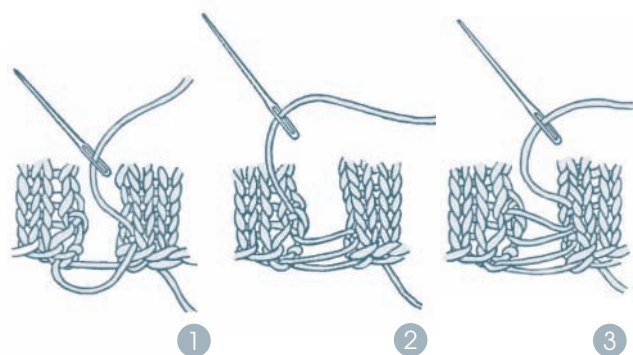

(Also called mattress stitch or ladder stitch.) With the right side of the knitting facing you, use a threaded needle to pick up one bar between the first two stitches on one piece (1), then the corresponding bar plus the bar above it on the other piece (2). *Pick up the next two bars on the first piece, then the next two bars on the other (3). Repeat from * to the end of the seam, finishing by picking up the last bar (or pair of bars) at the top of the first piece. To reduce bulk, pick up the bars in the center of the edge stitches instead of between the last two stitches. To prevent a half-row displacement at the seam, be sure to start the seam by picking up just one bar on the first side, then alternate two bars on each side.

short-rows: wrapping a stitch

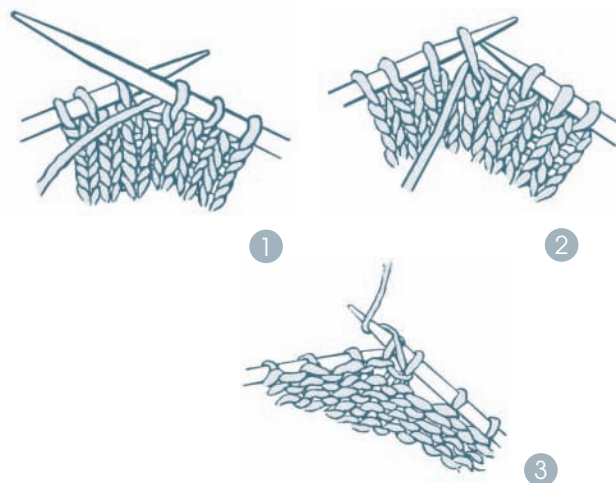

Work to turn point, slip the next stitch purlwise to right needle and bring the yarn to front (1), return the same stitch to the left needle (2), turn work, and bring yarn in position for the next stitch. When the work is turned to work back in the other direction, there will be one complete wrap encircling the base of the wrapped stitch.

When you come to a wrapped stitch on a subsequent row, work the wrapped stitch together with its wrap as follows: *Knit stitch*: Insert right needle tip into the front of the wrap(s) from below, then into the knit stitch as usual. Work the stitch and the wrap(s) together as k2tog or k3tog, depending on the number of wraps. *Purl stitch*: Insert the right needle tip into the back of the wrap from below and lift the wrap onto the left needle. Purl the stitch and the wrap(s) together as if to p2tog or p3tog, depending on the number of wraps.

make a pom-pom

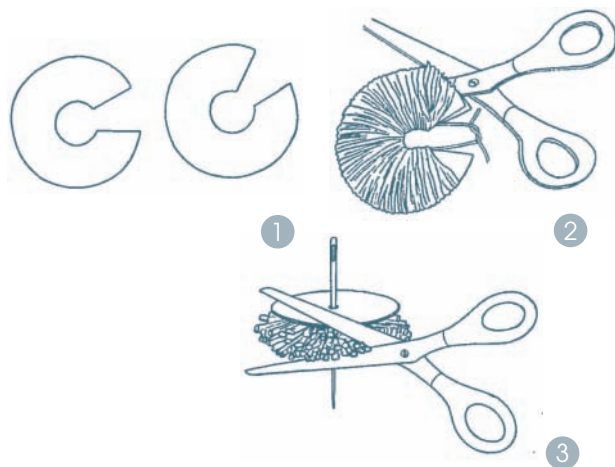

Cut two circles of cardboard, each $\frac{1}{2}$ " (1.3 cm) larger than desired finished pom-pom width. Cut a small circle out of the center and a small wedge out of the side of each circle (1). Tie a strand of yarn between the circles, hold the circles together and wrap them with yarn—the more wraps, the thicker the pom-pom. Cut between the circles and knot the tie strand tightly (2). Place pom-pom between two smaller cardboard circles held together with a tapestry needle and trim the edges (3). This technique comes from *Nicky Epstein's Knitted Embellishments* (Interweave Press, 1999).

crochet

crochet chain (ch)

Make a slipknot on hook. *Yarn over hook and draw it through loop of slipknot. Repeat from *, drawing yarn through the last loop formed.



single crochet (sc)

*Insert hook into a stitch, yarn over hook and draw a loop through stitch, yarn over hook (1) and draw it through both loops on hook (2). Repeat from *.

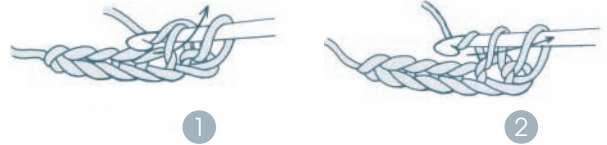

slip stitch crochet (sl st)

*Insert hook into stitch, yarn over hook and draw loop through stitch and loop on hook. Repeat from *.



half double crochet (hdc)

*Yarn over hook, insert hook into a stitch (1), yarn over hook and draw a loop through stitch (2), yarn over hook and draw it through all loops on hook (3). Repeat from *.

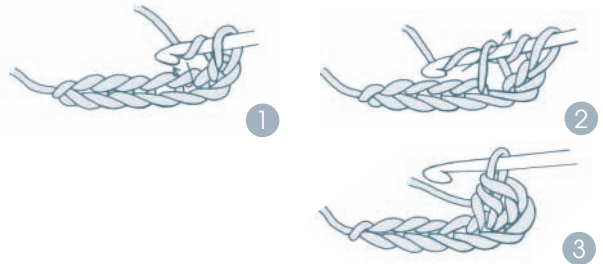

double crochet (dc)

*Yarn over hook, insert hook into a stitch (1), yarn over hook and draw a loop through stitch, yarn over hook and draw it through two loops (2), yarn over hook and draw it through remaining two loops (3). Repeat from *.

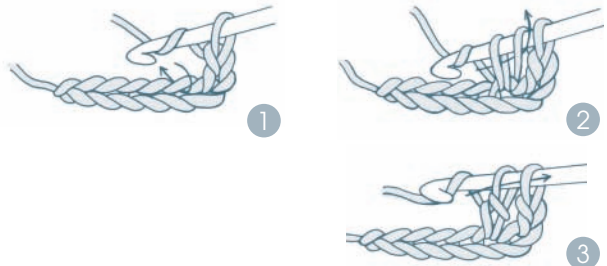

triple crochet (tr)

*Wrap yarn around hook two times, insert hook into a stitch (1), yarn over hook, and draw a loop through, yarn over hook and draw it through two loops (2), yarn over hook and draw it through the next two loops (3), yarn over hook and draw it through the remaining two loops (4). Repeat from *.

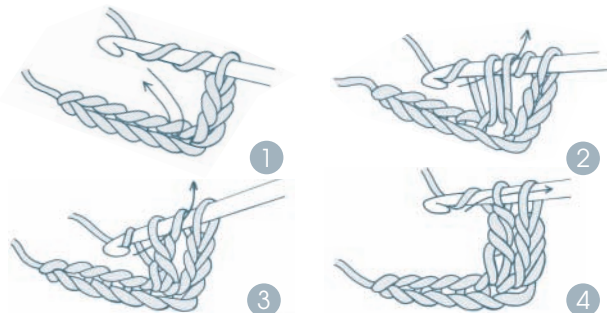

●●○○ I'm ready to move past scarves

size it

36 (40, 44½, 48½, 53)" (91.5 [101.5, 113, 123, 134.5] cm) bust circumference. Jacket shown measures 36" (91.5 cm).

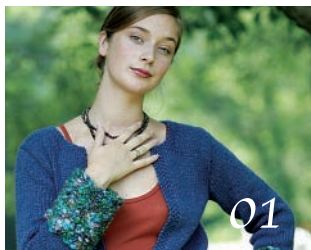

gather it

yarn • Tahki Bunny (50% wool, 25% alpaca, 25% acrylic; 81 yd [74 m]/50 g): #07 blue (MC), 9 (10, 12, 13, 14) balls. Tahki Uma (60% wool, 18% acrylic, 15% mohair, 7% nylon; 38 yd [35 m]/50 g): #6 blue/green multi (CC), 2 (2, 3, 3, 3) balls. **needles** • Body and sleeves—Size 9 (5.5 mm). Cuffs—Size 10½ (6.5 mm). Belt—Size 8 (5 mm). Adjust needle size if necessary to obtain the correct gauge. **notions** • Markers (m); stitch holders; tapestry needle.

gauge it

15 sts and 22 rows = 4" (10 cm) in St st with Bunny on size 9 (5.5 mm) needles; 10 sts and 13½ rows = 4" (10 cm) in St st with Uma on size 10½ (6.5 mm) needles.

note it

seed stitch: (odd number of stitches)
all rows: *K1, p1; rep from * to last st, k1.

knit it

back • With Bunny and size 9 (5.5 mm) needles, CO 67 (75, 83, 91, 99) sts. Work seed st (see Note It) for 4 rows. Beg with a RS row, work in St st (knit RS rows; purl WS rows) until piece measures 14 (14, 15, 15, 16)" (35.5 [35.5, 38, 38, 40.5] cm) from CO, ending with a WS row.

shape armholes: BO 3 sts at beg of next 2 rows, then BO 2 sts at beg of foll 2 rows—57 (65, 73, 81, 89) sts rem. Dec 1 st at beg of next 4 (8, 12, 16, 20) rows—53 (57, 61, 65, 69)

sts rem. Cont even until armholes measure 6¼ (6¾, 7¼, 7¾, 8¼)" (16 [17, 18.5, 19.5, 21] cm), ending with a WS row.

shape neck: (RS) K11 (12, 13, 15, 16), place marker (pm), work seed st over center 31 (33, 35, 35, 37) sts, pm, k11 (12, 13, 15, 16). Cont in St st and seed st as established for 3 more rows, ending with a WS row. **Next row:** (RS) Knit to marker, slip marker (sl m), work 4 sts in seed st, join a second ball of yarn and BO center 23 (25, 27, 27, 29) sts, work 4 sts in seed st, sl m, knit to end—15 (16, 17, 19, 20) sts each side. Working each side separately, cont in St st and seed st as established for 2 more rows, ending with a RS row—armhole measures about 7½ (8, 8½, 9, 9½)" (19 [20.5, 21.5, 23, 24] cm). Place 15 (16, 17, 19, 20) sts for each shoulder on a holder.

right front • With Bunny and size 9 (5.5 mm) needles, CO 33 (37, 41, 45, 49) sts. Work seed st for 4 rows. **Next row:** (RS) Work 4 sts in seed st as k1, p1, k1, p1, pm, knit to end of row. **Next row:** Purl to marker, sl m, work seed st over last 4 sts as p1, k1, p1, k1. Cont as established, working 4 edge sts in seed st and rem sts in St st until piece measures 14 (14, 15, 15, 16)" (35.5 [35.5, 38, 38, 40.5] cm) from CO, ending with a RS row.

shape armhole: (WS) BO 3 sts, purl to marker, sl m, work 4 edge sts as established. Cont in patt as established, at armhole edge (beg of WS rows), BO 2 sts once, then BO 1 st 2 (4, 6, 8, 10) times—26 (28, 30, 32, 34) sts rem. Cont as established until armhole measures 4¼ (4¾, 5¼, 5¾, 6¼)" (11 [12, 13.5, 14.5, 16] cm), ending with a WS row.

shape neck: (RS) Work 4 sts in seed st as established, remove marker, cont in seed st over next 7 sts (11 sts total in seed st), pm, knit to end of row. Cont in St st and seed st as established for 3 more rows, ending with a WS row. **Next row:** (RS) BO 7 sts in seed st patt, work 4 sts in seed st, sl m, knit to end of row—19 (21, 23, 25, 27) sts rem. Work next WS row in patt as established. **Next row:** (RS) Work 4 sts in seed st, sl m, k2tog, knit to end of row—1 st dec'd. Work 1 WS row as established. Rep the last 2 rows 3 (4, 5, 5, 6) more times—15 (16, 17, 19, 20) sts rem. Work in patt as established, if necessary, until armhole measures 7½ (8, 8½, 9, 9½)" (19 [20.5, 21.5, 23, 24] cm). Place sts on holder.

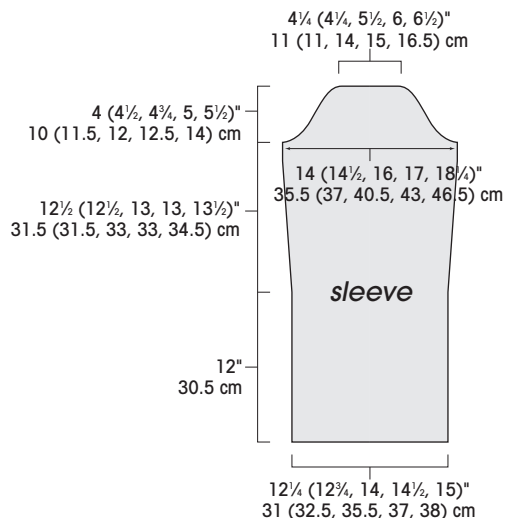
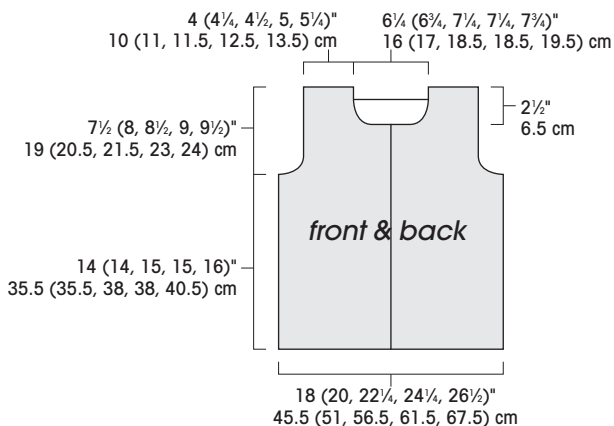



shop online
*purl*soho.com

visit our store

purl

137 SULLIVAN STREET, NEW YORK, NY 10012 (212) 420-8796

PHOTOGRAPH BY ANNA WILLIAMS FOR **LAST-MINUTE KNITTED GIFTS** PUBLISHED BY STEWART, TABORI & CHANG

left front • With Bunny and size 9 (5.5 mm) needles, CO 33 (37, 41, 45, 49) sts. Work seed st for 4 rows. *Next row:* (RS) Knit to last 4 sts, pm, work seed st as p1, k1, p1, k1. *Next row:* Work 4 sts in seed st as k1, p1, k1, p1, sl m, purl to end of row. Cont as established, working 4 edge sts in seed st and rem sts in St st until piece measures 14 (14, 15, 15, 16)" (35.5 [35.5, 38, 38, 40.5] cm) from CO, ending with a WS row.
shape armhole: (RS) BO 3 sts, knit to marker, sl m, work 4 edge sts as established. Cont in patt as established, at armhole edge (beg of RS rows), BO 2 sts once, then BO 1 st 2 (4, 6, 8, 10) times—26 (28, 30, 32, 34) sts rem. Cont as established until armhole measures 4¼ (4¼, 5¼, 5¼, 6¼)" (11 [12, 13.5, 14.5, 16] cm), ending with a RS row.
shape neck: (WS) Work 4 sts in seed st as established, remove marker, cont in seed st over next 7 sts (11 sts total in seed st), pm, purl to end of row. Cont in St st and seed st as established for 3 more rows, ending with a RS row. *Next row:* (WS) BO 7 sts in seed st patt, work 4 sts in seed st, sl m, purl to end of row—19 (21, 23, 25, 27) sts rem. Work next RS row in patt as established. *Next row:* (WS) Work 4 sts in seed st, sl m, ssp (see Know It, page 55), purl to end of row—1 st dec'd. Work 1 RS row as established. Rep the last 2 rows 3 (4, 5, 5, 6) more times—15 (16, 17, 19, 20) sts rem. Work in patt as established, if necessary, until armhole measures 7½ (8, 8½, 9, 9½)" (19 [20.5, 21.5, 23, 24] cm). Place sts on holder.

sleeves • With Bunny and size 9 (5.5 mm) needles, CO 46 (48, 52, 54, 56) sts. Beg with a RS row, work St st for 10 rows. *Inc row:* (RS) K2, M1 (see Know It, page 55), knit to last 2 sts, M1, k2—2 sts inc'd. Work 15 (15, 11, 9, 7) rows even in St st. Rep the last 16 (16, 12, 10, 8) rows 2 (2, 3, 4, 5) more times—52 (54, 60, 64, 68) sts. Cont even in St st until piece measures 12½ (12½, 13, 13, 13½)" (31.5 [31.5, 33, 33, 34.5] cm) from CO, ending with a WS row.
shape cap: BO 3 sts at beg of next 2 rows, then BO 2 sts at beg of foll 2 rows—42 (44, 50, 54, 58) sts rem. Dec 1 st each end of needle every RS row 6 (7, 8, 9, 10) times—30 (30, 34, 36, 38) sts rem. Work 1 WS row even. BO 2 sts at beg of next 4 rows, then BO 3 sts at beg of next 2 rows—16 (16, 20, 22, 24) sts rem. BO all sts.
Cuff: With Uma, size 10½ (6.5 mm) needles, and RS facing, pick up and knit sts across CO edge of sleeve as foll: pick up 1 st in edge st, skip 2 (1, 2, 1, 0) st(s), pick up in next st, skip 2 sts, [pick up in each of next 2 sts, skip 1 st] 12 (13, 14, 15, 16) times, pick up in next st, skip 2 sts, pick up in last st—28 (30, 32, 34, 36) sts. Work in rev St st (purl RS rows; knit WS rows) until cuff measures 12" (30.5 cm) from pick-up row for all sizes. Loosely BO all sts.

belt • With Bunny and size 8 (5 mm) needles, CO 11 sts.
 row 1: (RS) K2, [p1, k1] 4 times, k1.
 row 2: With yarn in front (wyf), sl 1 as if to purl, p1, [k1, p1] 4 times, end p1.
 row 3: With yarn in back (wyb), sl 1 as if to knit, k1, [p1, k1] 4 times, end k1.
 Rep Rows 2 and 3 until piece measures 60 (64, 68, 72, 78)" (152.5 [162.5, 172.5, 183, 198] cm) from CO. BO all sts in patt.

finish it

Block pieces gently to measurements. Use the three-needle

method (see Know It, page 54) to join fronts to back at shoulders. With yarn threaded on a tapestry needle, sew sleeve caps into armholes, matching center of caps with shoulder seams. Sew side and sleeve seams. Weave in loose ends. ☐

tweedy vest page 11

mona schmidt

●●●○ I'm feeling pretty confident

on the web knitscene.com

size it

30½ (34, 37½, 41, 44, 47½, 51)" (77.5 [86.5, 95, 104, 112, 120.5, 129.5] cm) bust/chest circumference. Vest shown measures 34" (86.5 cm).



gather it

yarn • Tahki Donegal Tweed (100% wool; 183 yd [167 m]/100 g): #804 eggplant, 3 (3, 4, 4, 4, 5, 5) skeins. ☐

chanel jacket page 12

deborah newton

●●●○ I'm feeling pretty confident

on the web knitscene.com

size it

34 (38, 42, 46, 50)" (86.5 [96.5, 106.5, 117, 127] cm) bust circumference. Jacket shown measures 34" (86.5 cm).



gather it

yarn • Filatura di Crosa Tokyo (55% extra-fine merino, 35% polyester, 10% polyamide; 71 yd [65 m]/50 g): #12 mauve tweed (MC), 10 (11, 13, 14, 15) balls. Stacy Charles Galaxy (50% viscose, 25% acrylic, 15% nylon, 5% polyester, 5% cupro; 92 yd [84 m]/50 g): #1 gold metallic (CC), 1 ball. Yarn distributed by Tahki/Stacy Charles. ☐

ruffle wrap page 13

teva durham

●●●● I'm ready for a challenge

size it

33 (35, 37½, 42, 46)" (84 [89, 95, 106.5, 117] cm) bust circumference, with non-ruffled edges of fronts overlapped by about 4¾" (12 cm) at center. Sweater shown measures 33" (84 cm). *Note:* Front overlap can be adjusted.



**R
U
S
S
I

S
A
L
E
S**



**Riviera
& Serpentine**

Quality Yarn & Knitting Accessories
Yarns from New Zealand, France & Australia
INOX

RussiSales.com 360.738.1455 retailers only please

FRENCH GIRL
DESIGNS IN KNIT & CROCHET



WWW.FRENCHGIRLKNITS.COM
206.860.2147

Shirley



Designed exclusively
for Louet Sales by
Leigh Radford



Sample Cards: \$10.00 / set.

Louet Sales: 808 Commerce Park Dr.
Station KC Ogdensburg, NY 13669
Canada: R.R. #4, Prescott ON K0E 1T0

www.louet.com

dealer inquiries welcome

Liz



gather it

yarn • GGH Soft Kid (70% mohair, 25% nylon, 5% wool; 154 yd [141 m]/25 g): #56 wine, 11 (11, 12, 13, 13) balls (used double). Yarn distributed by Muench Yarns.

needles • Size 11 (8 mm): 32" (80 cm) circular (cir). Adjust needle size if necessary to obtain the correct gauge.

notions • Markers (m); tapestry needle; size J/10 (6 mm) crochet hook.

gauge it

15 sts and 18 rows = 4" (10 cm) in St st with yarn doubled.

note it

The sweater body is knitted in one piece to armholes, then divided for fronts and back, which are worked separately to the shoulder.

The ruffle at right front edge is worked in short-rows (see Know It, page 56).

The main fabric of the body and sleeves is worked with two strands of yarn held together; the ruffles are worked with one strand.

stockinette and short-row ruffle pattern sequence:

row 1: (RS) K16 for ruffle with single strand of yarn, slip marker (sl m), pick up second strand of yarn, knit to end with both strands held tog.

row 2: Purl to ruffle with both strands of yarn held tog, sl m, drop one strand of yarn, p16 for ruffle with single strand of yarn. Cont with short-rows using single strand of yarn as foll:

short-rows 1 and 2: K14 (2 sts before ruffle marker), wrap next st (see Know It, page 56), turn work, purl to end.

short-rows 3 and 4: K10, wrap next st, turn work, purl to end.

short-rows 5 and 6: K6, wrap next st, turn work, purl to end.

short-rows 7 and 8: K2, wrap next st, turn work, purl to end.

short-rows 9 and 10: Rep Short-rows 7 and 8.

For the foll short-rows, work all wrapped sts tog with their wraps as you come to them (see Know It, page 56).

short-rows 11 and 12: Rep Short-rows 5 and 6.

short-rows 13 and 14: Rep Short-rows 3 and 4.

short-rows 15 and 16: Rep Short-rows 1 and 2.

One complete patt sequence consists of Rows 1 and 2 worked across all sts followed by Short-rows 1–16 worked across ruffle sts only—2 rows St st with doubled strand of yarn completed in main fabric areas; 18 rows (Rows 1 and 2, plus 16 short-rows) with single strand of yarn completed in ruffle area for each full rep of patt sequence.

knit it

lower body • With 2 strands of yarn held tog, CO 166 (174, 182, 198, 214) sts. Work back and forth in rows as foll:

Set-up row: (WS) P44 (46, 48, 52, 56), place marker (pm) for left side seam, p66 (70, 74, 82, 90) for back, pm for right side seam, p40 (42, 44, 48, 52) for right front, pm for ruffle, drop one strand of yarn, p16 for ruffle with single strand of yarn. Slip markers (sl m) on foll rows. Work 2 complete stockinette and short-row ruffle patt sequences (see Note It)—5 rows of main fabric completed (including set-up row); two 16-row short-row sequences completed; piece measures about 1" (2.5 cm) from CO along unruffled left front edge.

shape waist: Keeping in patt as established, cont as foll: *Dec row:* (Row 1 of patt sequence) Knit to 2 sts before right side seam marker, ssk (see Know It, page 55), sl m, k2tog, knit to 2 st before left side seam marker, ssk, sl m, k2tog, knit to end—4 sts dec'd. Complete this patt sequence, then work 1 more entire patt sequence without shaping. Cont in patt, rep the shaping of the last 2 patt sequences 5 more times (working dec row on Row 1 of every other patt sequence)—142 (150, 158, 174, 190) sts rem; 14 patt sequences total from beg; piece measures about 6½" (16.5 cm) from CO along unruffled left front edge. *Inc row:* (Row 1 of patt sequence) Knit to 1 st before right side seam marker, knit into the front and back of the next st (k1f&b), sl m, k1f&b, knit to 1 st before left side seam marker, k1f&b, sl m, k1f&b, knit to end—4 sts inc'd. Complete this patt sequence, then work 2 more entire patt sequences without shaping. Cont in patt, rep the shaping of the last 3 patt sequences 3 more times—158 (166, 174, 190, 206) sts total; 42 (44, 46, 50, 54) sts for left front, 62 (66, 70, 78, 86) sts for back, 38 (40, 42, 46, 50) sts for right front, 16 sts for ruffle; piece measures about 11¾" (30 cm) from CO along unruffled left front edge. Cont even in patt until piece measures 14" (35.5 cm) from CO along unruffled left front edge for all sizes, ending with RS Row 1 of patt sequence.

divide for armholes: (WS, Row 2 of patt sequence) P39

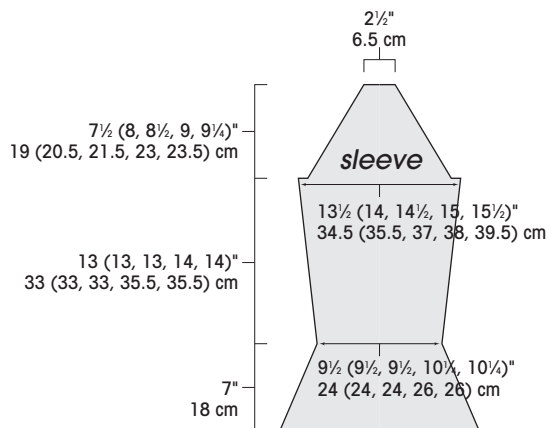
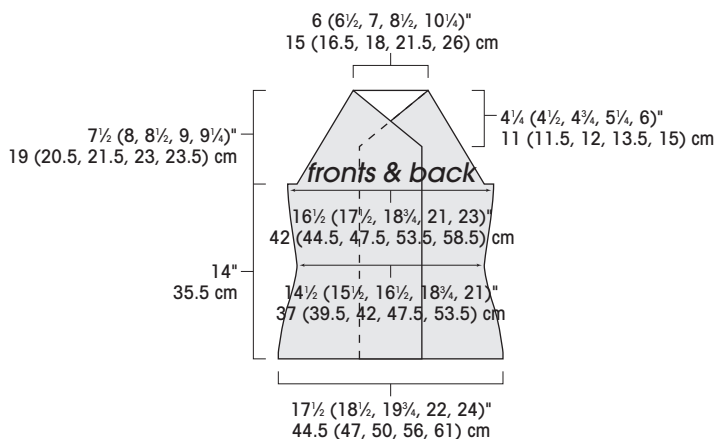

THE Web•sters

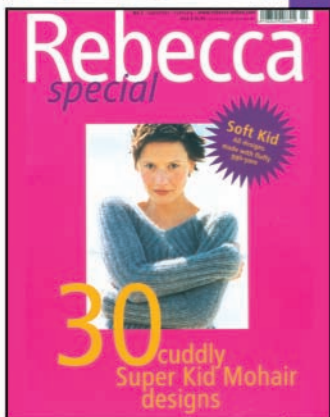

Rebecca Soft Kid Special
\$16.95 plus S&H

Order from our Website
www.yarnatwebsters.com

THE WEB•STERS

11 N. Main St., Ashland, OR
1-800-482-9801

Lana Grossa
Debbie Bliss
Jo Sharp
Jamieson's
Rowan
Fiesta Yarns
Jaeger
Koigu
Trendsetter
Heirloom
Plymouth
Mission Falls
Brown Sheep
Vittadini
Manos
Colinette
Mountain Colors
Knit One, Crochet Two
Dale of Norway
Green Mountain
Berroco
Classic Elite
Prism
Noro
GGH/Muench
Brittany Needles
Anny Blatt
Great Adirondack
Tahki • Stacy Charles



To discover what the magic is all about,
download free knitting patterns, and find
out if Cat is teaching a workshop near
you, visit WWW.CATBORDHI.COM



"The Little Wrap"
One of 16 sweaters featured in
Handknit Style, Contemporary Sweaters from Tricoter



Full range of TSC yarns available at Tricoter

TRICOTER

KNITTING SPECIALISTS

3121 E. Madison Street • Seattle, WA 98112
206.328.6505 • 877.554.9276 • tricoter@tricoter.com
Please visit our Web site at www.tricoter.com

(41, 43, 47, 51) for left front, BO 6 sts for left armhole, work until there are 56 (60, 64, 72, 80) sts on needle for back, BO 6 sts for right armhole, work in patt to end. Place sts for left front and back on holders—51 (53, 55, 59, 63) sts rem for right front; 35 (37, 39, 43, 47) sts in St st main fabric plus 16 sts for ruffle.

right front • Cont to end of current patt sequence on ruffle sts. shape armhole: Beg with RS Row 1 of the next patt sequence, dec 1 st at armhole edge (end of main fabric RS rows) on Row 1 of patt sequence 7 times—44 (46, 48, 52, 56) sts rem for right front; 28 (30, 32, 36, 40) sts in St st main fabric, 16 sts for ruffle. Cont to end of current patt sequence. *Note:* Raglan armhole shaping continues at the same time as neck shaping is introduced; read the next sections all the way through before proceeding.

shape neck: Beg with RS Row 1 of next patt sequence, BO 16 ruffle sts with single strand of yarn, remove ruffle marker, knit to end with 2 strands of yarn, dec 1 st at armhole edge for armhole shaping—27 (29, 31, 35, 39) sts rem. Cont in St st, dec 1 st at armhole edge (end of RS rows) 9 (10, 11, 12, 13) more times, and dec 1 st at neck edge (beg of RS rows; end of WS rows) every row 18 (19, 20, 23, 26) times—no sts rem when all armhole and neck shaping has been completed; armhole measures about 7½ (8, 8½, 9, 9¼)" (19 [20.5, 21.5, 23, 23.5] cm) from dividing row, measured straight up along a single column of sts (do not measure along raglan diagonal).

back • Return 56 (60, 64, 72, 80) held sts for back to needle, and rejoin 2 strands of yarn with RS facing, ready to work a RS row. Cont as foll:

shape armholes: Cont in St st, dec 1 st at each end of needle every RS row 17 (18, 19, 20, 21) times—22 (24, 26, 32, 38) sts rem; armholes measure about 7½ (8, 8½, 9, 9¼)" (19 [20.5, 21.5, 23, 23.5] cm) from dividing row, measured straight up along a single column of sts. BO all sts.

left front • Return 39 (41, 43, 47, 51) held sts for left front to needle and rejoin 2 strands of yarn with RS facing, ready to work a RS row. Cont as foll:

shape armhole: Cont in St st, dec 1 st at armhole edge (beg of RS rows) 7 times—32 (34, 36, 40, 44) sts rem.

Note: Raglan armhole shaping continues at the same time as neck shaping is introduced; read the next sections all the way through before proceeding.

shape neck: At beg of next WS row, BO 2 sts, purl to end—30 (32, 34, 38, 42) sts rem. Cont in St st, dec 1 st at armhole edge (beg of RS rows) 10 (11, 12, 13, 14) more times, and *at the same time* dec 1 st at neck edge (end of RS rows; beg of WS rows) every row 20 (21, 22, 25, 28) times—no sts rem when all armhole and neck shaping has been completed; armhole measures about 7½ (8, 8½, 9, 9¼)" (19 [20.5, 21.5, 23, 23.5] cm) from dividing row, measured straight up along a single column of sts.

sleeves • ruffle cuff: With 2 strands of yarn held tog, CO 18 sts. Work back and forth in rows as foll: *Set-up row:* (WS) P2, pm for ruffle, drop one strand of yarn, p16 for ruffle with single strand of yarn. Work in stockinette and short-row ruffle patt sequence until piece measures 10 (10, 10, 11, 11)"

(25.5 [25.5, 25.5, 28, 28] cm) from CO along unruffled selvedge, ending by having completed the last patt sequence. BO all sts.

arm: With RS facing and 2 strands of yarn held tog, pick up and knit 36 (36, 36, 38, 38) sts along straight edge of ruffle. Work 1 WS row even. Cont in St st, inc 1 st each end of needle on next RS row, then work 5 rows even—2 sts inc'd. Cont in St st, rep the shaping of the last 6 rows 6 (7, 8, 8, 9) more times—50 (52, 54, 56, 58) sts. Work even until piece measures 13 (13, 13, 14, 14)" (33 [33, 33, 35.5, 35.5] cm) from pick-up row, ending with a WS row.

shape cap: BO 3 sts at beg of next 2 rows—44 (46, 48, 50, 52) sts rem. Dec 1 st each end of needle every other row 17 (18, 19, 20, 21) times—10 sts rem for all sizes; cap measures about 7½ (8, 8½, 9, 9¼)" (19 [20.5, 21.5, 23, 23.5] cm). BO all sts.

finish it

With single strand of yarn threaded on a tapestry needle, sew raglan and sleeve seams.

edging: With RS facing, join double strand of yarn to edge of right front neck, just above where ruffle sts were BO. With crochet hook and RS facing, work 1 row of single crochet (see Know It, page 57) up right side of neck, across back neck, down shaped side of left front neck, down straight selvedge of left front opening, and across lower body edge to beg of ruffle at lower edge of right front; do not work single crochet around any parts of the ruffle. Fasten off last st. Weave in loose ends.

ties: (make 2) With 2 strands of yarn held tog, make a crochet chain 18" (45.5 cm) long, or desired length. Sew one tie to WS of right front where the main fabric meets the ruffle, or wherever best fit is achieved, and about 8" (20.5 cm) up from the lower edge, or even with the smallest part of the wearer's waist. Sew the other tie to the selvedge of the left front opening the same distance up from lower edge. Wear with ruffled right front overlapping plain left front, and secure with ties for best fit. ☐

tweed jacket page 14

leslie scanlon

●●●● I'm ready for a challenge

on the web knitscene.com

size it

36½ (37½, 40, 42½, 45, 47½)" (92.5 [95, 101.5, 108, 114.5, 120.5] cm) bust circumference. Jacket shown measures 42½" (108 cm).

gather it

yarn • Classic Elite Inca Alpaca (100% alpaca; 109 yd [100 m]/50 g): #1130 dahlia (pink), 10 (12, 13, 14, 16, 17) skeins. Classic Elite La Gran (76.5% mohair, 17.5% wool, 6% nylon; 90 yd [82 m]/42 g): #63508 dark sunset, 6 (7, 8, 9, 10, 10) skeins. ☐





View the full line of knitting patterns and find a retail source near you at www.chrisbylsmadesigns.com

Retailers: For wholesale inquiries, call 608-233-3967 or email chris@chrisknit.com

*Hand knit artwear.
Created by you.*

Chris Bylsma Designs

734 Miami Pass • Madison, WI 53711

knitting central
where creativity comes in endless colors
Tues, Wed, Fri 10-6pm • Thurs 10-7pm • Sat 10-5pm • Sun 12-4
203.454.4300 • 582 Post Road East, Westport (near Mitchells)
www.knittingcentral.com

- Addi Turbo
- Artyarns
- Berroco
- Cascade
- Cherry Tree Hill
- Crystal Palace
- Debbie Bliss
- Denise
- Filatura Di Crosa
- Gedifra
- Himalaya
- Karabella
- Katia
- Lana Grossa
- Lorna's Laces
- Lantern Moon
- Muench
- Needful Yarns
- Noro
- Prism
- Rio de la Plata
- Rowan
- Sirdar
- South West
- S. Charles
- Tahki
- Twisted Sisters

"I am delighted with your product selection, your website and your service. I will be a customer from here on out!!"

— Dorothy, PA

"Hats off to Yarnmarket!! I just received my first order and had to let you know how pleased I am. Your website is attractive, the selection and ordering process was simple and shipping was prompt. I shall return!!"

— Nora, CA

"You are by far my favorite knitting site on the web. Your selection is great. You offer lots of project ideas. And I receive my items very quickly."

— Tracy, IL

yarnmarket.com

Fabulous fashions. Fast. And friendly.

Begin your holiday celebration at Yarnmarket.com. You'll find over 500 festive projects — easy to find online under categories like *Glitz & Glamour*, *Gifts to Create*, and *Holiday Décor*. Complete projects are in stock and ready to ship the next business day. We also have books, accessories and over 250 fabulous yarn styles. For happy holiday knitting, visit www.yarnmarket.com today.

For assistance or to place a telephone order, call 888-996-9276. Outside the U.S., call 614-861-7223.



For affordable fashions — and fast and friendly service — make us your online favorite.

neck warmer page 15

emily bixler

●○○○ I've learned the basic stitches

size it

About 3¾" (9.5 cm) wide and 28" (71 cm) long at longer edge.

gather it

yarn • Classic Elite Inca Alpaca (100% alpaca; 109 yd [100 m]/50 g); #1198 persimmon, 2 skeins. **needles** • Size 10 (6 mm). Adjust needle size if necessary to obtain the correct gauge. **notions** • Tapestry needle.



gauge it

13½ sts and 11 rows = 2" (5 cm) in k1, p1 rib, relaxed, with yarn doubled.

knit it

With 2 strands of yarn held tog, CO 25 sts. *Set-up row*: *K1, p1; rep from * to last st, k1. Work in rib as established (knit the knits; purl the purls) for 15 more rows—piece measures about 3" (7.5 cm) from CO.

shape slits: Keeping in rib patt as established, make slits as foll:

row 1: (RS) Work 3 rib sts, BO 7 sts, work 15 rib sts.

row 2: Work 15 rib sts, use the backward loop method (see Know It, page 54) to CO 7 sts, work 3 rib sts.

rows 3 and 4: Work 2 rows even in rib.

row 5: Work 15 rib sts, BO 7 sts, work 3 rib sts.

row 6: Work 3 rib sts, use the backward loop method to CO 7 sts, work 15 rib sts.

Work even in rib until piece measures 11" (28 cm) from CO, ending with a WS row.

divide tails: Divide for two "tails" as foll: (RS) Work 11 rib sts, BO 3 sts, work 11 rib sts—11 sts each side. Working with the group of sts where the yarn is attached, cont in rib as established until this side of piece measures 28" (71 cm) from CO. BO all sts in rib patt. Rejoin yarn to other group of 11 sts with WS facing, and work these sts even in rib until this side of piece measures 26½" (67.5 cm) from CO. BO all sts.

finish it

Weave in loose ends. To wear, wrap scarf around neck, and thread tails through slits. □

alpaca gloves page 15

leslie scanlon

●●●○ I'm feeling pretty confident

size it

6½ (7, 8)" (16.5 [18, 20.5] cm) hand circumference. To fit a woman's small (medium, large) hand.

gather it

yarn • Classic Elite Inca Alpaca (100% alpaca; 109 yd [100 m]/50 g); #1130 dahlia (pink; MC), 2 skeins. Classic Elite Minnie (38% nylon, 23% polyester, 23% kid mohair, 16% merino; 120 yd [110 m]/50 g); #6089 pink priority (CC), 1 ball. **needles** • Hand and fingers—Size 3 (3.25 mm): set of 4 double-pointed (dpn). Cuff—Size 6 (4 mm): set of 4 dpn. Adjust needle size if necessary to obtain the correct gauge. **notions** • Markers (m); stitch holders or waste yarn; tapestry needle.



gauge it

12½ sts and 16 rnds = 2" (5 cm) in St st worked in the rnd on smaller needles.

note it

Both gloves are worked identically and can be worn on either hand.

knit it

hand • With MC and smaller dpn, CO 41 (44, 50) sts. Divide sts as evenly as possible on 3 dpn, place marker (pm), and join for working in the rnd, being careful not to twist sts. Work even in St st (knit every rnd) until piece measures 1 (1¼, 2)" (2.5 [4.5, 5] cm) from CO.

shape thumb gusset: Knit into front and back of same st (k1f&b), k1, k1f&b, pm, knit to end of rnd—2 sts inc'd; 5 gusset sts between markers. Knit 2 rnds even. *Inc rnd*: K1f&b, knit to 1 st before gusset marker, k1f&b, knit to end—2 sts inc'd between markers. Rep the last 3 rnds 3 (4, 5) more times—13 (15, 17) gusset sts between markers; 51 (56, 64) sts total. *Next rnd*: Place 13 (15, 17) gusset sts on holder or waste yarn to be worked later for thumb, use the backward loop method (see Know It, page 54) to CO 3 sts over gap, knit to end of rnd—41 (44, 50) sts.

upper hand: Work even until piece measures 1¾ (2, 2¼)" (4.5 [5, 5.5] cm) from CO sts at top of thumb gusset.

little finger • (*Note*: The fingers are worked one at a time, starting with the little finger; the remaining hand sts are placed on holders for the palm and back of hand. These stitches will be transferred to the needles as they are needed for the other fingers.) K16 (17, 19) and place sts just worked on holder or waste yarn, k9 (10, 12) sts for little finger, place rem 16 (17, 19) sts on holder or waste yarn. Use the backward loop method to CO 3 sts at end of little finger sts—12 (13, 15) sts total for little finger. Distribute sts as evenly as possible on 3 dpn, pm, and join for working in the rnd. Work even until finger measures about 2 (2¼, 2½)" (5 [5.5, 6.5] cm), or about ¼" (6 mm) less than desired total length.

shape tip: [K2tog, k1] 4 (4, 5) times, k0 (1, 0)—8 (9, 10) sts rem. *Next rnd*: [K2tog] 4 (4, 5) times, k0 (1, 0)—4 (5, 5) sts rem. Cut yarn, thread tail on a tapestry needle, draw through rem sts 2 times, and fasten off to inside.

ring finger • Slip the next 5 (5, 6) sts from each holder onto



StitchDC

*DC's source for knitting & crochet
yarns, books, tools, and community.*

NOW TWO LOCATIONS:

CAPITOL HILL

731 8th St. SE, Washington, DC

202.544.8900

GEORGETOWN

1071 Wisconsin Ave. NW, Washington, DC

202.333.5648

www.stitchdc.com

Why would you
settle for
less than the best?



**FRIENDLY
PRODUCTS**

Sweater Soap

Fine Fabric Wash

for a retail store near you call

1-800-544-8992

**Look Who's Got
Knitting Yarns!**

**Anneke's
Needleworks**
for memories that last

**Florida's
Knitting
&
Needlework
Headquarters**

**We can meet all of your
knitting & needlepoint needs!**

305.665.6222
5851 Sunset Drive
South Miami, FL 33143

shop online: annekesneedleworks.com



Bathtime Blossoms

by Evelyn A. Clark for

Fiber Trends[®]

To find a store near you visit

www.fibertrends.com

Retailers, for wholesale information contact:
Bryson Distributing @ 1.800.544.8992
or Fiber Trends @ 1.888.733.5991

PO Box 7266 • E. Wenatchee, WA 98802
(509) 884-8631

info@fibertrends.com

a dpn—10 (10, 12) sts on 2 dpn. With RS facing, join yarn to beg of sts CO at base of little finger. Pick up and knit 3 sts at base of the little finger, k5 (5, 6) from dpn, use the backward loop method to CO 3 sts, k5 (5, 6) from dpn—16 (16, 18) sts. Distribute sts as evenly as possible on 3 dpn. Pm and join for working in the rnd. Work even until finger measures about 2½ (2¾, 3)" (6.5 [7, 7.5] cm), or about ¼" (6 mm) less than desired total length.

shape tip: [K2tog, k1] 5 (5, 6) times, k1 (1, 0)—11 (11, 12) sts rem. *Next rnd:* [K2tog] 5 (5, 6) times, k1 (1, 0)—6 sts rem for all sizes. Finish as for little finger.

middle finger • Slip the next 5 (5, 6) sts from each holder onto a dpn. Join yarn to beg of sts CO at base of ring finger. Pick up and knit 3 sts at base of ring finger, k5 (5, 6) from dpn, use the backward loop method to CO 4 sts, k5 (5, 6) from dpn—17 (17, 19) sts. Distribute sts as evenly as possible on 3 dpn. Pm and join for working in the rnd. Work even until finger measures 2¼ (3, 3¼)" (7 [7.5, 8.5] cm), or about ¼" (6 mm) less than desired total length.

shape tip: [K2tog, k1] 5 (5, 6) times, [k2tog] 1 (1, 0) time(s), k0 (0, 1)—11 (11, 13) sts rem. *Next rnd:* [K2tog] 5 (5, 6) times, k1 (1, 1)—6 (6, 7) sts rem. Finish as for little finger.

index finger • Slip rem 12 (14, 14) sts onto 2 dpn—6 (7, 7) sts on each needle. Join yarn to beg of sts CO at base of middle finger. Pick up and knit 4 sts from base of middle finger, k12 (14, 14)—16 (18, 18) sts. Distribute sts as evenly as possible on 3 dpn. Pm and join for working in the rnd. Work even until finger measures 2½ (2¾, 3)" (6.5 [7, 7.5] cm), or about ¼" (6 mm) less than desired total length.

shape tip: [K2tog, k1] 5 (6, 6) times, k1 (0, 0)—11 (12, 12) sts rem. *Next rnd:* [K2tog] 5 (5, 6) times, k1 (0, 0)—6 sts rem for all sizes. Finish as for little finger.

thumb • Place 13 (15, 17) held thumb sts on 2 dpn. With a third dpn, pick up and knit 3 sts from sts CO for thumb gap—16 (18, 20) sts. Distribute sts as evenly as possible on 3 dpn. Pm and join for working in the rnd. Work even until thumb measures 2 (2¼, 2½)" (5 [5.5, 6.5] cm), or about ¼" (6 mm) less than desired total length.

shape tip: [K2tog, k1] 5 (6, 6) times, [k2tog] 0 (0, 1) time(s), k1 (0, 0)—11 (12, 13) sts rem. *Next rnd:* [K2tog] 5 (6, 6) times, k1 (0, 1)—6 (6, 7) sts rem. Finish as for little finger.

cuff • With larger dpn and CC, CO 17 (17, 19) sts. Work in rows as foll:

row 1: (RS) K2 (2, 3), slip 1 st purlwise with yarn in back, knit to end.

row 2: (WS) Purl.

Rep Rows 1 and 2 until cuff measures 7 (7½, 8½)" (18 [19, 21.5] cm) from CO. Slip a third dpn into the base of each CO st to pick up 17 (17, 19) sts; these sts are just picked up without working them, not picked up and knitted. Fold the cuff in half with the RS of the fabric on the inside and WS facing you. Use the three-needle method (see Know It, page 54) to BO the beg and end of cuff tog. The slipped st near the beg of the RS rows produces a slightly rolled finished edge that will be at the bottom of the glove when pieces are sewn tog.

finish it

Place plain selvedge edge (without the rolled finish) of cuff and CO edge of glove together with RS of fabrics touching, and BO cuff seam centered on the little finger. With yarn threaded on a tapestry needle, sew CO edge of glove to selvedge of cuff. Weave in loose ends. Block lightly. ☐

clutch purse page 16

●●○○ I'm ready to move past scarves

size it

11" (28 cm) wide at top, 13" (33 cm) wide at base, and 6½" (16.5 cm) high.

gather it

yarn • Muench Cleo (87% rayon, 13% metal: 62 yd [56 m]/50 g): #158 sanny, 2 balls.

needles • Bag—Sizes 7 and 9 (4.5 and 5.5 mm): straight. I-cord—Size 6 (4 mm): set of 2 double-pointed (dpn). Adjust needle size if necessary to obtain the correct gauge. **notions** • Tapestry needle; 24" (61 cm) ½" (1.3-cm) diameter dowel; ½ yd (.5 meter) lining fabric; 21" (53.5 cm) Lucite chain; magnetic snap (chain and snap available from Sunbelt Fastener; www.sunbeltfashion.com).

gauge it

15 sts and 22½ rows = 4" (10 cm) in k1, p1 rib with larger needles.

knit it

With smaller needles, CO 42 sts. Beg with a RS row, work rev St st (purl RS rows, knit WS rows) for 11 rows, ending with a RS row. Using the backward loop method (see Know It, page 54), CO 3 sts at end of last row worked—45 sts. Turn work. *Next row:* (WS) K2, M1 (see Know It, page 55), *[k1, p1] 3 times, M1, p1; rep from * to last st, k1—52 sts. Using the backward loop method, CO 3 sts—55 sts. *Next row:* (RS) P4, *k1, p1; rep from * to last 3 sts, p3. *Next row:* K4, *p1, k1; rep from * to last 3 sts, k3. Change to larger needles and rep the last 2 rows until piece measures 5½" (14 cm) from beg of rib patt, ending with a RS (purl) row. *Next row:* (WS) Knit. *Next row:* (RS) BO 4 sts, knit to end—51 sts rem. *Next row:* BO 4 sts, purl to end—47 sts rem. Work 4 more rows in St st, ending with a WS (purl) row. Using the backward loop method, CO 4 sts—51 sts. Turn work. *Next row:* (RS) P4, *k1, p1; rep from * to last st, k1. Use the backward loop method to CO 4 sts—55 sts. Turn work. *Next row:* (WS) K4, *p1, k1; rep from * to last 3 sts, k3. Cont in rib and rev St st patt until ribbed portion measures 2 rows shorter than ribbed portion of opposite side of purse, ending with a RS row. Change to smaller needles and work 1 more row as established. *Dec row:* (RS) BO 3 sts (1 st rem on right needle), k1, p1, k2tog, *[k1, p1] 3 times, k2tog; rep from * 4 more times, ending k1, p1, k2tog, p3—45 sts rem. *Next row:* (WS) BO 3 sts, knit to end—42 sts rem. Work 10 rows even in rev St st. BO all sts.



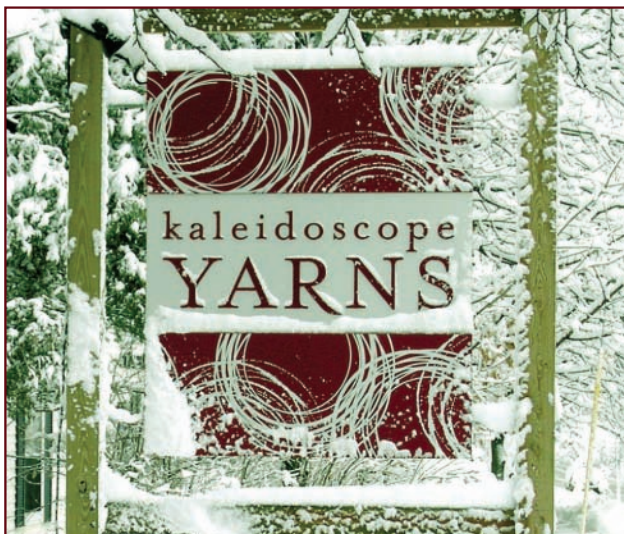

Vermont's best yarn shop
Shipping thousands of orders worldwide

www.kyarns.com

Now through 12/31/05, shop online and receive 10% off
(use coupon code KSI)

WEBS™

America's Yarn Store...

www.yarn.com

Service, Selection and Value...
that's WEBS.

We carry a wide selection of
yarns from Tahki/Stacy Charles
and Classic Elite.

save up to
25% off
your next
yarn order

75 SERVICE CENTER ROAD NORTHAMPTON, MASSACHUSETTS
1.800.367.9327

Yarn Knit Supplies DVDs Books Patterns

SUSS

each product uniquely created
with innovation craft and love

RETAIL - LA

7350 beverly blvd. la. ca 90036 323.954.9637 (tel) 9674 (fax)
lastore@sussdesign.com

RETAIL - NY

281 lafayette st. ny. ny 10012 212.226.1848 (tel) 1827 (fax)
nystore@sussdesign.com

WHOLESALE

6013 west olympic blvd. la. ca 90036 323.954.9650 (tel) 9652 (fax)
yarn@sussdesign.com



SUSS

Call or visit us at
www.sussdesign.com

finish it

Using the bag as a template, cut one lining piece $\frac{1}{2}$ " (1.3 cm) larger than bag dimensions. With yarn threaded on a tapestry needle and RS tog, sew sides of bag. Matching seams to center of bottom panel, stitch corners of bag, sew bottom of side panels to bottom panel. Sew side seams and corners of lining same as for bag. With WS tog, sew lining to bag at top edges, leaving rev St st strips free. Fold CO and BO edges of rev St st strip to inside, just overlapping lining, and sew down through both lining and bag. Cut dowel into two pieces, each the length of the rev St st tube, and insert. Sew ends of tube over dowels to secure. Center one piece of magnetic snap to center of dowel and sew in place. Align other half of snap on opposite dowel and sew in place.

I-cord loops: With dpn, CO 3 sts. Work I-cord as foll: *k3, with RS still facing, slide sts to right needle tip, draw yarn around behind work in preparation for working another RS row; rep from * until cord measures 2" (5 cm). BO all sts. Fold I-cord in half to form a loop, and stitch down at end of one dowel. Rep for other dowel, stitching I-cord to opposite end of second dowel. Attach chain to bag, fitting end links inside each I-cord loop. ☐

pom-pom hat page 17

●●○○ I'm ready to move past scarves

size it

18 $\frac{3}{4}$ " (47.5 cm) circumference. To fit an adult.

gather it

yarn • Filatura Di Crosa Curley (60% wool, 25% viscose, 15% acrylic; 44 yd [40 m]/50 g): #138 burgundy/brown tweed (MC), 2 balls; #142 peacock/pink tweed (CC), 1 ball. Yarn distributed by Tahki/Stacy Charles. needles • Size 11 (8 mm). Adjust needle size if necessary to obtain the correct gauge. notions • Tapestry needle; smooth yarn in matching color for seaming.



gauge it

8 $\frac{1}{2}$ sts = 4" (10 cm) in reverse St st.

knit it

CO 40 sts. Work in rev St st (purl RS rows; knit WS rows) until piece measures 15" (38 cm) from CO. BO all sts.

finish it

With RS (purl side) facing tog, fold hat rectangle in half lengthwise (Figure 1). With smooth yarn threaded on a tapestry needle, sew BO and selvedge edges. With WS (knit side) facing out, measure up 9" (23 cm) from cast-on edge and fold cast-on edge of hat (with WS tog) to 9" (23 cm) line (Figure 2) and tack down. Measure down 3" (7.5 cm) from tacked down, CO edge of hat. Turn hat RS out. With RS facing out, open out double layer of hat and fold along the 3" (7.5 cm) line to create a 4 $\frac{1}{2}$ " (11.5 cm) cuff around lower edge (Figure 3). Tack down the top cuff 1 $\frac{1}{2}$ " (3.8 cm) from top fold. Cuff will be 2 layers at lower edge; 3 layers at top edge.

hat assembly

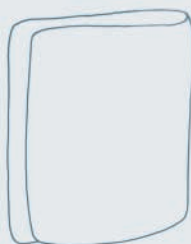

- 1 fold in half lengthwise then sew BO and selvedge edges

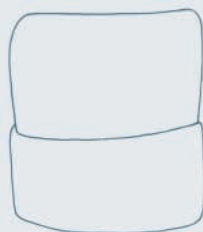

- 2 fold lower edge up 9" (23 cm)



- 3 open out double layer to create 4 $\frac{1}{2}$ " (11.5 cm) cuff

pom-poms: With one strand each of MC and CC, make two 3" (7.5-cm) pom-poms (see Know It, page 56).

twisted cord: Cut one 20" (51-cm) length each of MC and CC. Knot the two yarns tog at one end. Place the knotted end over a doorknob. Hold one strand in each hand, twist each strand clockwise until the strands kink on themselves. Hold the two loose ends together in one hand, use the other hand to remove the knotted end from the doorknob, and allow the two strands to twist against each other. Sew one pom-pom to each end of cord, fold cord in half and stitch fold of cord to center of seam at hat top. Tuck in 2" (5 cm) along seam line at hat top and tack loosely to inside. ☐



Journey to New Zealand

with Interweave April 13–30, 2006
OPTIONAL EXTENSION TO AUSTRALIA
APRIL 30–MAY 7, 2006

- Travel with Jane and Nola Fournier
- Attend the Creative Fibre Festival in Napier, Art Deco capital of New Zealand
- Experience working sheep stations
- Immerse yourself in Maori culture, local handcrafts, and fantastic shopping
- Treat yourself to beautiful yarn and wool found on the spectacular North and South Islands

For details, send a business-sized SASE to
New Zealand Journey
2610 Gold Rush Ave.
Helena, MT 59601
or e-mail nzjourney@bresnan.net

photos courtesy of Jude Aves, Catherine Aves and Amy Clarke



Paradise Fibers

www.paradisefibers.com

1.888.320.SPIN (7746)

Spokane, WA

**20% off
Surina
wood needles**

**LARGE SELECTION
OF YARNS FROM
Muench Yarns
Kollage Yarns
Wool in the Woods
AND MANY MORE**

**"Romance" from
Kollage Yarns**



Inspiring Yarns...
Irresistible Prices



elann.com

Peruvian Collection 100% Highland Wool
in a Designer's Palette of 98 Colors

Just \$2.25 per 50g ball!

Highland Wool Ribby Cardi, above, designed
by Bonne Marie Burns of ChicKnits.com

Register at www.elann.com to receive a free
introductory copy of our newsletter with samples

fair isle duet page 20

teva durham

●●●○ I'm feeling pretty confident

size it

Pullover—35¼ (52¾)" (89.5 [134] cm) chest circumference. Sweater shown measures 35¼" (89.5 cm). Hat—18" (45.5 cm) circumference with ribbing relaxed; can stretch to 23" (58.5 cm).



gather it

yarn • Classic Elite Montera (50% llama, 50% wool; 127 yd [116 m]/100 g). Pullover—#3829 aqua ice (MC), 9 (13) skeins (used double); #3862 kingfisher blue (turquoise, B), #3854 Alice blue heather (C), and #3816 Lapaz natural (D), 1 skein each (used double). Hat—1 skein each of MC, B, C, and D (used double). **needles** • Size 11 (8 mm): 32", 24", and 16" (80, 60, and 40 cm) circular (cir), and set of 4 double-pointed (dpn). Adjust needle size if necessary to obtain the correct gauge. **notions** • Markers (m); tapestry needle.

gauge it

10 sts and 13 rows = 4" (10 cm) in St st worked in the rnd with yarn doubled.

note it

All yarn colors are used doubled throughout.

When working the Fair Isle chart in the round, read all chart rows from right to left.

Strand the nonworking colors loosely across the WS of the work so fabric lies flat and does not pucker (see It's Worth It, page 34).

The planned length for this garment from shoulder to lower edge is about 26 (28)" (66 [71] cm). Because size 52¾" has a much deeper yoke than size 35¼", the larger size has a shorter length from cast-on edge to the beginning of the yoke.

The planned cuff-to-cuff "wingspan" for this garment is about 57½ (62½)" (146 [158.5] cm). Because size 52¾" has a significantly wider body than size 35¼", the larger size has shorter sleeves.

knit it

pullover body • With 2 strands of MC held tog and longest cir needle, CO 90 (135) sts. Place marker (pm) and join for working in the rnd, being careful not to twist sts. *Next rnd:* *K3, p2; rep from * to end of rnd. Cont in rib as established until piece measures 4" (10 cm) from CO, dec 2 (3) sts evenly spaced on last rnd—88 (132) sts rem. Work even in St st (knit all rnds) until piece measures 6½" (16.5 cm) from CO. Beg with Rnd 1, work 22-st rep of Fair Isle chart (page 74) 4 (6) times across. Cont in patt from chart until Rnd 15 has been completed. Break off other colors and cont in St st with MC until piece measures 20 (17¼)" (51 [44] cm) from CO. *divide for armholes:* K42 (63), BO 4 (6) sts, knit to last 2 (3) sts of rnd, BO last 2 (3) sts of this rnd and first 2 (3) sts of next rnd—40 (60) sts rem in each group for front and back. Cut yarn. Set aside.

sleeves • With 2 strands of MC held tog and dpn, CO 25 sts. Pm and join for working in the rnd, being careful not to twist sts. Work k3, p2 rib as for body until piece measures 4" (10 cm) from CO, dec 3 sts evenly spaced on last rnd—22 sts rem. Cont in St st until piece measures 6½" (16.5 cm) from CO. Beg with Rnd 1, work 22-st rep of Fair Isle chart across all sts. Cont in patt from chart until Rnd 15 has been completed—piece measures about 11" (28 cm) from CO. Break off other colors and cont in St st with MC, and *at the same time* inc 1 st each side of end-of-rnd marker on next rnd—2 sts inc'd. Work 3 (1) rnd(s) even. Rep the shaping of the last 4 (2) rnds 3 (9) more times, changing to shortest cir when necessary—30 (42) sts. Work even until sleeve measures 20 (18)" (51 [45.5] cm) from CO.

divide for armhole: Knit to last 2 sts, BO last 2 sts of this rnd and first 2 sts of next rnd—26 (38) sts rem. Cut yarn. Set aside. Make another sleeve to match, leaving sts on needle.

yoke • Return one group of 40 (60) body sts to longest cir needle with RS facing. Join 2 strands MC to beg of first group of sts (back right shoulder) and pm for beg of rnd. *Joining rnd:* Work 40 (60) back sts as p2, k36 (56), p2; knit across 26 (38) sts of sleeve on shortest cir; return rem group of 40 (60) body sts to needle and work across them as p2, k36 (56), p2; return 26 (38) sts for second sleeve to needle and knit across them—132 (196) sts total. *Next rnd:* *P2, k2, pm, ssk (see Know It, page 55), k28 (48), k2tog, pm, k2, p2, k2, pm, ssk, k18 (30), k2tog, pm, k2; rep from * once more—124 (188) sts rem. Work 1 rnd even in patt (knit the knits, and purl the purls). *Dec rnd:* *P2, k2, slip marker (sl m), ssk, knit to 2 sts before next marker, k2tog, sl m, k2, p2, k2, sl m, ssk, knit to 2 sts before next marker, k2tog, sl m, k2; rep from * once more—8 sts dec'd. Work 1 rnd even in patt. Cont in patt, rep the shaping of the last 2 rnds 7 (14) more times, changing to progressively shorter cir needles when necessary—60 (68) sts rem; piece measures about 6 (10¼)" (15 [26] cm) from joining rnd, and about 26 (27½)" (66 [70] cm) from CO, measured straight up a single column of sts at center front or back (do not measure along diagonal raglan decrease lines). *For size 52¾" only:* Work 1 more dec rnd as foll: *P2, k2, sl m, ssk, k16, k2tog, sl m, k2, p2, k1, ssk (remove marker between the 2 sts worked tog), k2tog (remove marker between 2 sts worked tog), k1; rep from * once more—60 sts rem for both sizes. *For size 52¾" only:* Work 1 more rnd even. Piece measures about 6 (10¾)" (15 [27.5] cm) from joining rnd, and about 26 (28)" (66 [71] cm) from CO, measured straight up a single column of sts at center front or back.

collar: Set up rib patt for your size as foll:

Size 34¼": *P2, k3; rep from * to end.

Size 52¾": * [P2, k2] 6 times, [p2, k1] 2 times; rep from * once more.

Cont in rib as established until collar measures 5" (12.5 cm). BO all sts in patt.

finish it

Weave in loose ends. With yarn threaded on a tapestry needle, sew seams at underarms. Block lightly.

hat • With 2 strands of MC held tog and shortest cir needle, CO 45 sts. Place marker (pm) and join for working in the rnd,

Huge selection of basic, designer and hand-dyed yarns, books, and other fiber art supplies.

Fabulous yarns by Noro, Great Adirondack, Koigu, Colinette, Ellen's Originals, Rowan, Crystal Palace & many more.

Knit and Stitch
=Bliss™

Order by Phone Toll-Free:
1•866•5NEEDLE

Mention code KSF05 and get FREE shipping

Internet supplier @ www.knitandstitch.com
4706 Bethesda Ave. Bethesda, MD 0814 301•652•8688

Colorful STITCHES

48 Main St., Lenox, MA
www.colorful-stitches.com 800-413-6111

experience a new level of knitting

Purl's
the yarn studio™

4800 Mills Civic Parkway, Ste. 104
West Des Moines, Iowa 50265
www.purlsthe yarnstudio.com • 515.223.9000

knit. anew.

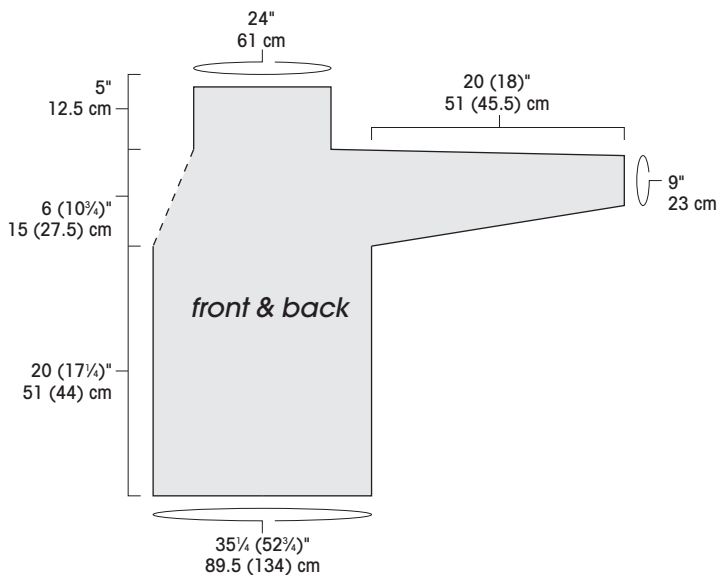

fair isle

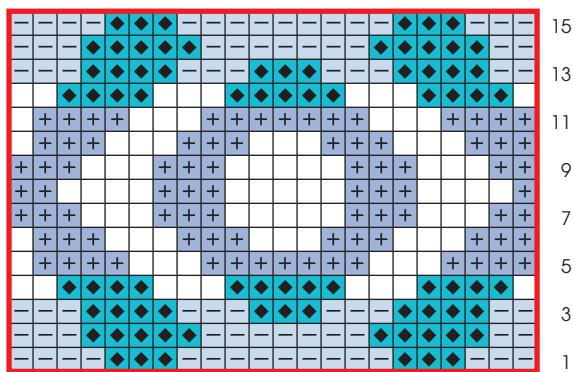

start hat

- aqua ice (MC)
- natural (D)
- turquoise (B)
- pattern repeat
- blue heather (C)

being careful not to twist sts. *Next rnd:* *K3, p2; rep from *. Cont in rib as established until piece measures 1" (2.5 cm) from CO.

shape back: Keeping in rib patt, work back and forth in short-rows (see Know It, page 56) as foll:

short-row 1: (RS) Work 24 sts, wrap next st, turn work around.

short-row 2: (WS) Work 22 sts in rib patt to 2 sts before end-of-rnd marker, wrap next st, turn.

short-row 3: Work 20 sts to 2 sts before last wrapped st, wrap next st, turn.

short-row 4: Work 18 sts to 2 sts before last wrapped st, wrap next st, turn.

short-row 5: Work 16 sts to 2 sts before last wrapped st, wrap next st, turn.

short-row 6: Work 14 sts to 2 sts before last wrapped st, wrap next st, turn.

short-row 7: Work 12 sts to 2 sts before last wrapped st, wrap next st, turn.

short-row 8: Work 10 sts to 2 sts before last wrapped st, wrap next st, turn—4 wrapped sts at each side.

Next row: (RS) Work in rib as established to end-of-rnd marker, working wrapped sts tog with their wraps as you come to them (see Know It, page 56). Work 1 more rnd in rib, working any rem wrapped sts tog with their wraps, and dec 1 st—44 sts rem; piece measures about 1½" (3.8 cm) from CO at shallowest point, and 4" (10 cm) at deepest point (center back). Work 1 rnd even in St st (knit every rnd). Beg with Rnd 1, establish patt from Fair Isle chart as foll: Beg at start point for hat, work 12 sts to end of chart, work entire 22-st rep once, then work the first 10 sts of chart once to finish at the start point. Cont in patt from chart as established until Rnd 15 has been completed. Break off other colors and cont in St st with MC for 2 more rnds—piece measures about 7" (18 cm) from CO at shallowest point.

shape crown: *K2, k2tog; rep from * to end of rnd, changing to dpn if necessary—33 sts rem. Work 1 rnd even. *Next rnd:* *K1, k2tog; rep from *—22 sts rem. Work 1 rnd even. *Next rnd:* *K2tog; rep from *—11 sts rem. Cut yarn, leaving a 12" (30.5-cm) tail. Thread tail on a tapestry needle, draw through rem sts, pull tight, and fasten off to WS. Weave in loose ends. □

posh cardigan page 21 norah gaughan

●●●○ I'm feeling pretty confident

size it

33½ (38, 42, 46½, 50½)" (85 [96.5, 106.5, 118, 128.5] cm) bust circumference. Cardigan shown measures 38" (96.5 cm).

gather it

yarn • Classic Elite Posh (30% cashmere, 70% silk; 125 yd [114 m]/50 g): #93053

needles • Body and sleeves—ocean, 7 (8, 9, 10, 11) skeins. **ribbing**—Size 5 (3.75 mm). Adjust needle size if necessary to obtain the correct gauge. **notions** • Tapestry needle.

gauge it

19 sts and 28 rows = 4" (10 cm) in St st on larger needles.

knit it

back • With smaller needles, CO 90 (102, 110, 122, 134) sts. *Set-up rib:* (WS) *P2, k2; rep from * to last 2 sts, p2. Cont in rib as established until piece measures 1½" (3.8 cm) from



• Alchemy • Artyarns • Blue Sky Alpaca • Cascade •



Knit Happens
Nirvana for Knitters

Shop in person ...
www.knithappens.net
... Shop online!

127A N. Washington St.
Alexandria, VA 22314
USA
703-836-0039



Shipping Yarn
Around the World!

Koigu • Lorna's Laces • Lantern Moon • Manos •
Crystal Palace • Debbie Bliss • Gedifra • Fiesta • Jaeger • Katia • Karabella •
Mission Falls • Regia • Rowan • Tahki/S. Charles • And More!

BRITTANY

brittanyneedles.com

**KNITTING
NEEDLES
CROCHET
HOOKS**

made in
Northern California
of sustainably harvested
domestic birch
hardwood

One Family
Thirty Years

New York's Premiere Yarn Shop Is Online at: **theyarnco.com**

■ yarn ■ projects ■ books ■ instruction ■ nyc location

- Largest stock of **Filatura Di Crosa's Zara** in the U.S.
- Broad selection of **Tahki/Stacy Charles, Muench** and other fine yarns.

Call toll free at (888) YARNCO1 • (212) 787-7878

The Yarn Co. • 2274 Broadway (bet. 81 & 82 St.) • NYC 10024

*When placing your next order, mention Code KS1 to receive a one time 10% discount.
Discount offer expires 2/15/06*

CO, ending with a WS row. *Next row:* (RS) Change to larger needles and St st, and dec 10 (12, 10, 12, 14) sts evenly spaced—80 (90, 100, 110, 120) sts rem. Work even in St st until piece measures 8" (20.5 cm) from CO, ending with a WS row.

shape armholes: BO 4 sts at beg of next 0 (0, 0, 2, 4) rows, then BO 3 sts at beg of foll 0 (2, 4, 4, 2) rows, then BO 2 sts at beg of foll 4 (4, 2, 2, 2) rows—72 (76, 84, 86, 94) sts rem. *Next row:* (RS) K3, k2tog, knit to last 5 sts, ssk (see Know It, page 55), k3—2 sts dec'd. Work 1 WS row even. Rep the last 2 rows 1 (1, 2, 1, 2) more time(s)—68 (72, 78, 82, 88) sts rem. Work even until armholes measure 8 (8½, 9, 9½, 10)" (20.5 [21.5, 23, 24, 25.5] cm), ending with a WS row.

shape shoulders and neck: Mark center 14 sts. With RS facing, BO 5 (5, 6, 8, 9) sts, work to marked sts, join a new ball of yarn and BO center 14 sts, knit to end. With WS facing, BO 5 (5, 6, 8, 9) sts, purl to end of first group of sts, purl second group of sts—22 (24, 26, 26, 28) sts rem for each side. Working each side separately, at each neck edge, BO 6 sts 2 times, and *at the same time*, at each armhole edge, BO 5 (6, 7, 8) sts 2 times.

left front • With larger needles, CO 5 sts. Working in St st, use the backward loop method (see Know It, page 54) to CO 5 sts at end of every RS row 7 (8, 9, 10, 11) times—40 (45, 50, 55, 60) sts. Cont even in St st for 1 (1, 1, 3, 3) more row(s), ending with a WS row—piece measures 2¼ (2½, 2¾, 3½, 3¾)" (5.5 [6.5, 7, 9, 9.5] cm) from CO at side edge.

shape neck: (RS) Knit to last 5 sts, ssk, k3—1 st dec'd. Dec 1 st at neck edge in this manner every RS row 5 (3, 1, 0, 0) more time(s), then every 4th row 13 (15, 17, 18, 18) times, and *at the same time*, when piece measures 8" (20.5 cm) from CO at side edge, *shape armhole as foll:*

shape armhole: At armhole edge (beg of RS rows), BO 4 sts 0 (0, 0, 1, 2) time(s), then BO 3 sts 0 (1, 2, 2, 1) time(s), then BO 2 sts 2 (2, 1, 1, 1) time(s). *Next RS row:* K3, k2tog, knit to end—1 st dec'd. Work 1 WS row even. Rep the last 2 rows 1 (1, 2, 1, 2) more time(s). Work even at armhole edge (cont with neck shaping until complete, then work even) until armhole measures 8 (8½, 9, 9½, 10)" (20.5 [21.5, 23, 24, 25.5] cm), ending with a WS row—15 (17, 20, 22, 25) sts rem

after all neck and armhole shaping is completed.

shape shoulder: At armhole edge (beg of RS rows) BO 5 (5, 6, 8, 9) sts once, then BO 5 (6, 7, 7, 8) sts 2 times.

right front • With larger needles, CO 5 sts. Working in St st, use the backward loop method to CO 5 sts at end of every WS row 7 (8, 9, 10, 11) times—40 (45, 50, 55, 60) sts. Cont even in St st for 1 (1, 1, 3, 3) more row(s), ending with a WS row—piece measures 2¼ (2½, 2¾, 3½, 3¾)" (5.5 [6.5, 7, 9, 9.5] cm) from CO at side edge.

shape neck: (RS) K3, k2tog, knit to end—1 st dec'd. Dec 1 st at neck edge in this manner every RS row 5 (3, 1, 0, 0) more time(s), then every 4th row 13 (15, 17, 18, 18) times, and *at the same time*, when piece measures 8" (20.5 cm) from CO at side edge, *shape armhole as foll:*

shape armhole: At armhole edge (beg of WS rows), BO 4 sts 0 (0, 0, 1, 2) time(s), then BO 3 sts 0 (1, 2, 2, 1) time(s), then BO 2 sts 2 (2, 1, 1, 1) time(s). *Next WS row:* P3, p2tog, purl to end—1 st dec'd. Work 1 RS row. Rep the last 2 rows 1 (1, 2, 1, 2) more time(s). Work even at armhole edge (cont with neck shaping until complete, then work even) until armhole measures 8 (8½, 9, 9½, 10)" (20.5 [21.5, 23, 24, 25.5] cm), ending with a RS row—15 (17, 20, 22, 25) sts rem after all neck and armhole shaping is completed.

shape shoulder: At armhole edge (beg of WS rows), BO 5 (5, 6, 8, 9) sts once, then BO 5 (6, 7, 7, 8) sts 2 times.

sleeves • With smaller needles, CO 38 (42, 42, 46, 46) sts. *Set-up rib:* (WS) *K2, p2; rep from * to last 2 sts, k2. Cont in rib as established until piece measures 1½" (3.8 cm) from CO, ending with a WS row. *Next row:* (RS) Change to larger needles and St st, and inc 2 (0, 2, 0, 2) sts evenly spaced—40 (42, 44, 46, 48) sts. Work even in St st until piece measures 2½" (6.5 cm) from CO, ending with a WS row. *Next row:* (RS) K2, M1 (see Know It, page 55), knit to last 2 sts, M1, k2—2 sts inc'd. Work 13 (9, 9, 7, 7) rows even. Rep the last 14 (10, 10, 8, 8) rows 6 (8, 9, 11, 12) more times—54 (60, 64, 70, 74) sts. Cont even until piece measures 18" (45.5 cm) from CO, ending with a WS row.

shape cap: BO 3 sts at beg of next 2 rows, then BO 2 sts at beg of foll 2 rows—44 (50, 54, 60, 64) sts rem. *Next row:*

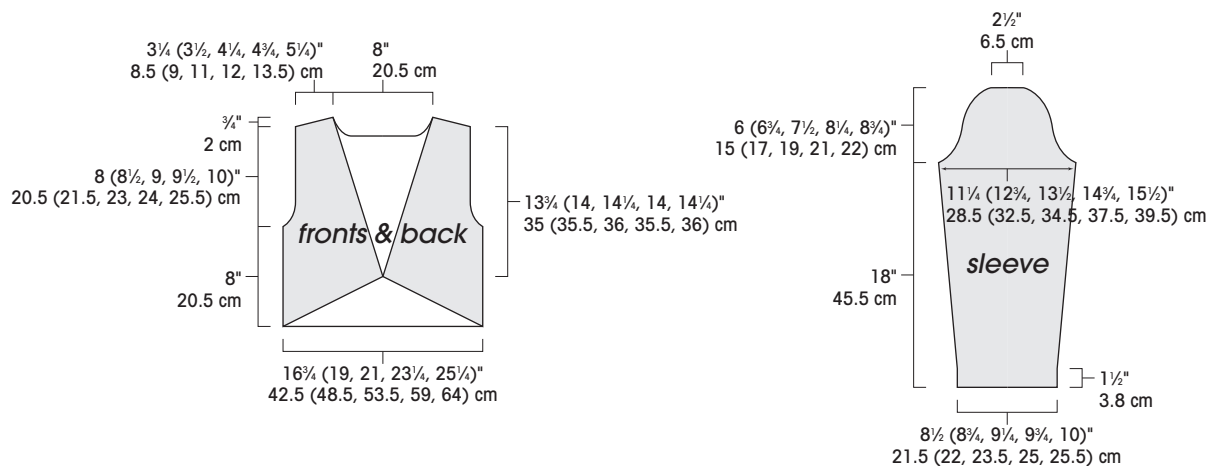

(RS) K3, k2tog, knit to last 5 sts, ssk, k3—2 sts dec'd. Dec 1 st each end of needle in this manner every RS row 2 (3, 4, 5, 6) more times, then every 4th row 6 times, then every RS row 2 (4, 5, 7, 8) times—22 sts rem for all sizes. BO 2 sts at beg of next 2 rows, then BO 3 sts at beg of foll 2 rows—12 sts rem. BO all sts.

finish it

left front bottom rib: With smaller needles and RS facing, pick up and knit 42 (46, 50, 58, 62) sts evenly spaced along bottom edge of left front. *Set-up rib:* (WS) *P2, k2; rep from * to last 2 sts, p2. *Next row:* (RS) K2, M1, work in rib to last 2 sts, M1, k2—2 sts inc'd. Work 1 WS row. Rep the last 2 rows 3 more times, working new sts in rib patt—50 (54, 58, 66, 70) sts. With RS facing, BO all sts.

right front bottom rib: Work as for left front bottom rib.

collar: With larger needles and RS facing, pick up and knit 190 (195, 200, 205, 210) sts evenly spaced along front and neck edges. K7, work in St st to last 7 sts, k7. Work even in St st, keeping first and last 7 sts in garter st, until piece measures 4½ (4½, 5, 5, 5½)" (11.5 [11.5, 12.5, 12.5, 14] cm) from pick-up, ending with a RS row. BO all sts knitwise.

With yarn threaded on a tapestry needle, sew sleeves into armholes. Sew sleeve and side seams. Weave in loose ends. Lightly steam-block as needed. ☐

mesh tunic page 22 doris chan

●●●○ I'm feeling pretty confident

size it

36 (40, 44)" (91.5 [101.5, 112] cm) bust circumference. Tunic shown measures 36" (91.5 cm).



gather it

yarn • Stacy Charles Ritratto (28% mohair, 53% rayon, 10% nylon, 9% polyester; 198 yd [180 m]/50 g): #78 blue, 3 (4, 5) balls. Yarn distributed by Tahki/Stacy Charles. hook • Size G/6 (4 mm). Adjust hook size if necessary to obtain the correct gauge. notions • Tapestry needle.

gauge it

6 mesh and 9 mesh rows (sc, ch 4) = 4" (10 cm) in smaller mesh patt; 5 mesh and 8 mesh rows (sc, ch 5) = 4" (10 cm) in larger mesh patt.

note it

The ch-4 at beg of each row forms a turning chain space (tch-sp) that is oddly shaped, elongated, and easily overlooked. Be sure to work that space at the end of the next row.

When worn, the first 3 rows of the fronts will fall to the back side of the garment, providing the back neck drop. In other words, the foundation chain will not sit on top of the shoulder, but will sit about 1¼" (3.2 cm) down the back.

The Best Things Come in "Little Boxes"



Slip a laminated project card into your yarn bag and go! Choose from classic to chic designs for sweaters, scarves, hats, throws, and much more—you'll find a favorite pattern in our popular "Little Box" series. 20 cards in each box! **\$19.95 each**

Available at your favorite yarn shop or book store.

Martingale[®]
& COMPANY

1-800-426-3126 • www.martingale-pub.com

AMERICA'S BEST-LOVED KNITTING BOOKS[®]

crochet it

back • Ch 50 (50, 56).

row 1: (RS) Sc in 5th ch from hook for tch-sp, [ch 4, skip next 2 ch, sc in next ch] 15 (15, 17) times, turn—16 (16, 18) ch-sp.

row 2: [Ch 4, sc in next ch-sp] 15 (15, 17) times, ch 4, sc in tch-sp, turn.

Rep Row 2 six more times—piece measures 3½" (9 cm) from foundation.

shape sides: Inc row: Ch 4, [sc, ch 4] 2 times in first ch-sp, *sc in next ch-sp, ch 4; rep from * to tch-sp, sc in tch-sp, turn—1 ch-sp inc'd. Rep inc row 6 (8, 8) more times, ending with a RS row—23 (25, 27) ch-sp. **Next row:** (WS) Ch 4, [sc, ch 4] 2 times in first ch-sp, *sc in next ch-sp, ch 4; rep from * to tch-sp, (sc, ch 4, sc) in tch-sp—25 (27, 29) ch-sp. Fasten off.

right front • (Worked onto foundation ch on right-hand side of back.) With RS of back facing, join yarn with a sl st in spare loop at beg of foundation ch.

row 1: Ch 4, sc in first ch-sp of foundation, [ch 4, sc in next ch-sp] 3 (3, 4) times—4 (4, 5) ch-sp. Turn.

rows 2–14: [Ch 4, sc in next ch-sp] 3 (3, 4) times, ch 4, sc in tch-sp, turn—piece should measure 6¼" (16 cm) from foundation ch after Row 14.

shape sides: Inc row: Ch 4, [sc, ch 4] 2 times in first ch-sp, *sc in next ch-sp, ch 4; rep from * to tch-sp, sc in tch-sp, turn—1 ch-sp inc'd. Rep inc row 6 (8, 8) more times, ending with a RS row—11 (13, 14) ch-sp. **Next row:** (WS) Ch 4, [sc, ch 4] 2 times in first ch-sp, *sc in next ch-sp, ch 4; rep from * to tch-sp, (sc, ch 4, sc) in tch-sp—13 (15, 16) ch-sp. Fasten off.

left front • With RS of back facing, skip next 8 ch-sp of foundation, join yarn with a sl st in next ch-sp.

row 1: Ch 4, sc in same ch-sp, [ch 4, sc in next ch-sp] 3 (3, 4) times—4 (4, 5) ch-sp. Turn.

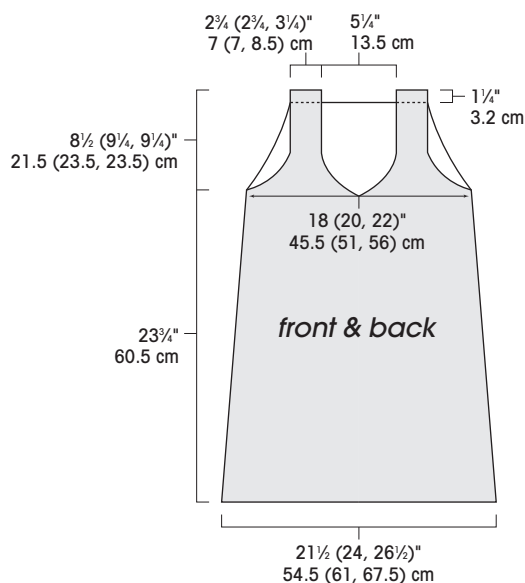

Work as for right front, reversing shaping by working inc row as [ch 4, sc in next ch-sp] across to tch-sp, [ch 4, sc] 2 times in tch-sp.

body • Join the fronts and back and work back and forth in rnds, with sts added for the underarms, as foll:

rnd 1: (RS) With RS facing, join yarn with a sl st in first ch-sp of back, ch 1, sc in same sp, [ch 4, sc in next ch-sp] 24 (26, 28) times across back, ch 11 (11, 14) for underarm, sc in first ch-sp of right front, [ch 4, sc in next ch-sp] 11 (13, 14) times, ch 4, sc tog last ch-sp of right front with first sp of left front, [ch 4, sc in next ch-sp] 12 (14, 15) times, ch 11 (11, 14) for underarm, sl st in beg sc of back, sl st in beg ch-sp of rnd, turn.

rnd 2: (WS) Ch 1, sc in same ch-sp, *[ch 4, skip next 2 ch of underarm, sc in next ch] 3 (3, 4) times, ch 4, skip last 2 ch of underarm*, sc in first ch-sp of front, [ch 4, sc in next ch-sp] across front, rep from * to * for underarm, sc in first ch-sp of back, [ch 4, sc in next ch-sp] across back, end ch 2, hdc in beg sc—54 (60, 66) ch-sp, turn.

rnd 3: Ch 1, sc in same sp, [ch 4, sc in next ch-sp] 53 (59, 65) times, ch 2, hdc in beg sc, turn.

rnds 4–24: Rep Rnd 3.

rnds 25–49: Ch 1, sc in same sp, [ch 5, sc in next ch-sp] 53 (59, 65) times, ch 2, dc in beg sc, turn.

rnd 50: (WS) Ch 1, sc in same sp, [ch 3, sc in next ch-sp] 53 (59, 65) times, ch 3, sl st in beg sc, turn.

rnd 51: Ch 1, sc in same sc, [2 sc in next ch-sp, sc in next sc] 53 (59, 65) times, 2 sc in next ch-sp, sl st in beg sc—162 (180, 198) sc. Fasten off.

finish it

neck edging: With RS facing, join yarn with a sl st in same ch-sp as worked for right front, ch 1, sc in same ch-sp, [sc in next spare loop of foundation, 2 sc in next ch-sp] 8 times, sc in next spare loop, sc in same ch-sp as worked for left front; along V-neck shaping, sc in each row-end sc, 2 sc in each ch-sp across to join at center front, sc3tog (over ch-sp of join, sc of join, and ch-sp other side of join), sc along V-neck as before, sl st in beg sc. Fasten off.

armhole edging: With RS facing, join yarn with a sl st in first ch-sp of underarm ch, ch 1, sc in same sp, [sc in next spare loop, 2 sc in next ch-sp] 3 (3, 4) times, sc in each row-end sc, 2 sc in each ch-sp around armhole, sc in same ch-sp as beg, sl st in beg sc. Fasten off.

Weave in loose ends. Block to measurements. □



●●●○ I'm feeling pretty confident

size it

Pullover—34 (37½, 42, 46)" (86.5 [95.5, 106.5, 117] cm) chest/bust circumference. Pullover shown measures 37½" (95.5 cm). Scarf—10" (25.5 cm) wide and 87" (221 cm) long.



gather it

yarn • Classic Elite Forbidden (100% cashmere; 65 yd [59 m]/50 g): #10051 sky, 8 (9, 11, 13) skeins for pullover; 6 skeins for scarf. **needles** • Pullover—Size 11 (8 mm): straight and 32" (80 cm) circular (cir). Scarf—Size 13 (9 mm): straight. Adjust needle size if necessary to obtain the correct gauge. **notions** • Stitch markers (m); a few yards of smooth worsted-weight waste yarn; tapestry needle.

gauge it

Pullover—12 sts and 18 rows = 4" (10 cm) in St st with smaller needles. Scarf—11 sts and 15 rows = 4" (10 cm) in rib patt on larger needles.

knit it

back • With smaller needles, CO 51 (56, 63, 69) sts. Beg with a RS (knit) row, work 8 (10, 12, 12) rows in St st, ending with a WS row—piece measures about 1¼ (2¼, 2¾, 2¾)" (4.5 [5.5, 7, 7] cm) from CO. *Dec row:* (RS) K2, k2tog, knit to last 4 sts, ssk (see Know It, page 55), k2—2 sts dec'd. Work 5 rows even in St st. Rep the last 6 rows 3 more times—43 (48, 55, 61) sts rem. Work 5 more rows even in St st. *Inc row:* (RS) K2, M1 (see Know It, page 55), knit to last 2 sts, M1, k2—2 sts inc'd. Work 5 rows even in St st. Rep the last 6 rows 3 more times—51 (56, 63, 69) sts. Work even in St st until piece measures 14 (15, 16, 17)" (35.5 [38, 40.5, 43] cm) from CO, ending with a WS row.

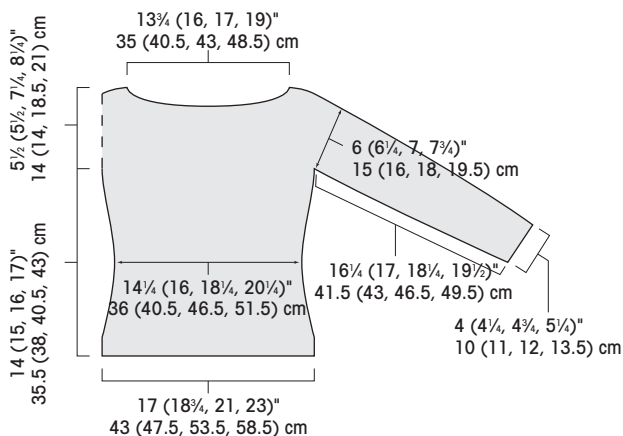

shape lower armhole: BO 3 sts at beg of next 2 rows—45 (50, 57, 63) sts rem. *Next row:* (RS) Ssk, knit to last 2 sts, k2tog—43 (48, 55, 61) sts rem. Place stitches on waste yarn to hold for later.

front • Work same as for back.

sleeves • (make 2) With smaller needles, CO 24 (26, 28, 32) sts. Beg with a RS (knit) row, work 12 (14, 14, 16) rows in St st, ending with a WS row—piece measures about 2¾ (3, 3, 3½)" (7 [7.5, 7.5, 9] cm) from CO. *Inc row:* (RS) K2, M1, knit to last 2 sts, M1, k2—2 sts inc'd. Inc 1 st at each end of needle in this manner every 10th row 5 (3, 6, 5) more times, then every 12th row 0 (2, 0, 1) time(s)—36 (38, 42, 46) sts. Work even in St st until piece measures 16¼ (17, 18¼, 19½)" (41.5 [43, 46.5, 49.5] cm) from CO, ending with a WS row.

shape lower armhole: BO 3 sts at beg of next 2 rows—30 (32, 36, 40) sts rem. *Next row:* (RS) Ssk, knit to last 2 sts, k2tog—28 (30, 34, 38) sts rem. Place stitches on waste yarn to hold for later.

yoke • Join sts on cir needle as foll: 28 (30, 34, 38) sts of one sleeve, 43 (48, 55, 61) sts of front, 28 (30, 34, 38) sts of second sleeve, and 43 (48, 55, 61) sts of back—142 (156, 178, 198) sts total. Join yarn, knit to last 2 sts of back, place marker (pm), k1, k2tog (last back st and first sleeve st), k1, pm, work to last 2 sts of sleeve, pm, k1, k2tog (last st of sleeve and first st of front), k1, pm, work to last 2 sts of front, pm, k1, k2tog (last st of front and first st of sleeve), k1, pm, knit to last 2 sts of sleeve, pm, k1, k2tog (last st of sleeve and first st of back), pm (marks beg of rnd), k1, pm—138 (152, 174, 194) sts rem; 3 sts between markers where sleeves meet front and back; 1 marker to indicate beg of rnd. Slip markers (sl m) every rnd.

rnd 1: Knit.
rnd 2: K1, sl m, *k2tog, knit to 2 sts before next marker, ssk, sl m, k3 to next marker, sl m; rep from * 3 more times, end last rep k2 to beg-of-rnd marker—8 sts dec'd.
rnds 3, 4, and 5: Knit.
 Rep Rnds 2–5 five (five, seven, eight) more times—90 (104, 110, 122) sts rem. Work Rnd 2 once more, and *at the same time* BO all sts.

finish it

Block pieces. With yarn threaded on tapestry needle, sew side and sleeve seams. Sew underarm seams. Weave in loose ends.

scarf • With larger needles, CO 36 sts.
 row 1: (RS) *K4, p4; rep from * to last 4 sts, k4.
 row 2: *P4, k4; rep from * to last 4 sts, p4.
 Rep these 2 rows until piece measures 87" (221 cm) from CO. BO all sts in patt. Weave in loose ends. □

●●●○ I'm feeling pretty confident

size it

42 (46, 50, 54)" (106.5 [117, 127, 137] cm) bust circumference. Sweater shown measures 46" (117 cm).



gather it

yarn • Black Forest Naturwolle (100% wool; 110 yd [101 m]/100 g): #U13 teal 12 (13, 15, 16) skeins (used doubled). Yarn distributed by Muench Yarns. **needles** • Size 17 (12.75 mm). Adjust needle size if necessary to obtain the correct gauge. **notions** • Removable markers or safety pins; tapestry needle; size N/P-15 (10 mm) crochet hook.

gauge it

8 sts and 11 rows = 4" (10 cm) in St st with yarn doubled.

knit it

back • With yarn doubled, CO 42 (46, 50, 54) sts. Beg with a RS row, work even in St st (knit RS rows; purl WS rows) until piece measures 22½ (23, 23½, 24)" (57 [58.5, 59.5, 61] cm) from CO, ending with a WS row. Mark last row for beg of armhole.

shape armholes: BO 3 sts at beg of next 2 rows, then BO 2 sts at beg of foll 2 rows—32 (36, 40, 44) sts rem. Dec 1 st at beg of next 2 (4, 4, 6) rows—30 (32, 36, 38) sts rem. Work even until armholes measure 8 (8, 9½, 10)" (20.5 [20.5, 24, 25.5] cm), ending with a WS row.

shape shoulders: (RS) Mark center 14 (14, 16, 16) sts. BO 4 (4, 5, 5) sts, knit to marked sts, join a second ball of yarn and BO center 14 (14, 16, 16) sts, knit to end. With WS facing, BO 4 (4, 5, 5) sts, purl to end of first group of sts, purl second group of sts—4 (5, 5, 6) sts rem for each side. Working each side separately, at each armhole edge, BO 4 (5, 5, 6) sts once.

right front • With yarn doubled, CO 14 (16, 17, 19) sts. Beg with a RS row, work even in St st until piece measures same length as back to armhole, ending with a RS row.

shape armhole: (WS) BO 3 sts, purl to end. Cont in St st, at armhole edge (beg of WS rows), BO 2 sts once, then dec 1 st 1 (2, 2, 3) time(s)—8 (9, 10, 11) sts rem. Cont even until armhole measures same length as back to shoulder, ending with a RS row.

shape shoulder: (WS) BO 4 (4, 5, 5) sts, work to end—4 (5, 5, 6) sts rem. At beg of next WS row, BO all sts.

left front • With yarn doubled, CO 14 (16, 17, 19) sts. Beg with a RS row, work even in St st until piece measures same length as back to armhole, ending with a WS row.

shape armhole: (RS) BO 3 sts, knit to end. Cont in St st, at armhole edge (beg of RS rows), BO 2 sts once, then dec 1 st 1 (2, 2, 3) time(s)—8 (9, 10, 11) sts rem. Cont even until armhole measures same length as back to shoulder, ending with a WS row.

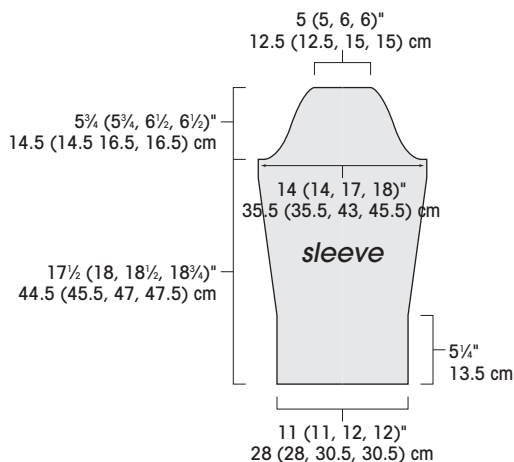
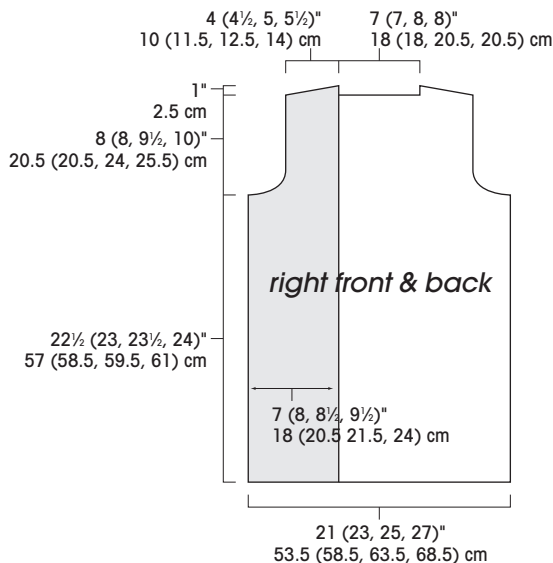

shape shoulder: (RS) BO 4 (4, 5, 5) sts, work to end—4 (5, 5, 6) sts rem. At beg of next RS row, BO all sts.

sleeves • (make 2) With yarn doubled, CO 22 (22, 24, 24) sts. Beg with a RS row, work even in St st until piece measures 5½" (13.5 cm) from CO, ending with a WS row. **Inc row:** (RS) K2, M1 (see Know It, page 55), work to last 2 sts, M1, k2—2 sts inc'd. Work 9 (11, 5, 5) rows even. Rep the last 10 (12, 6, 6) rows 2 (2, 4, 5) more times—28 (28, 34, 36) sts. Work even until sleeve measures 17½ (18, 18½, 18¾)" (44.5 [45.5, 47, 47.5] cm) from CO, ending with a WS row. **shape cap:** BO 3 sts at beg of next 2 rows—22 (22, 28, 30) sts rem. Dec 1 st each end of needle every other row 2 times, then every 6th row once, then every other row 1 (1, 2, 2) time(s)—14 (14, 18, 20) sts rem. BO 2 (2, 3, 4) sts at beg of next 2 rows—10 (10, 12, 12) sts rem. BO all sts.

finish it

Block pieces gently to measurements. With single strand of

yarn threaded on a tapestry needle, sew shoulder seams. Sew sleeve caps into armholes, matching center of caps to shoulder seams. Sew sleeve and side seams. Weave in loose ends. **crochet border:** With yarn doubled and crochet hook (see Know It, page 57, for crochet instructions) work border around cardigan edges as foll:

row 1: Join yarn with sl st in first st at bottom right front, ch 1, work 78 (78, 82, 82) sc evenly spaced along front edge, 16 (16, 19, 19) sc around neck edge, and 78 (78, 82, 82) sc evenly spaced down left front—172 (172, 183, 183) sc total. Turn.

row 2: Ch 1, sc in first st, [dc in next 5 sts, skip next st, sc in next st, ch 2, skip next 2 sts, sc in next st, skip next st] 15 (15, 16, 16) times, dc in next 5 sts, sc in last st—15 (15, 16, 16) ch-2 sp; 80 (80, 85, 85) dc. Turn.

row 3: Ch 1, sc in first st, *[dc in next dc, ch 1] 4 times, dc in next dc, sc in next ch-sp; rep from * 14 (14, 15, 15) more times, [dc in next dc, ch 1] 4 times, dc in next dc, sc in last st—17 (17, 18, 18) sc; 80 (80, 85, 85) dc. Turn.

row 4: Ch 1, sc in first st, [dc in next dc, ch 2] 4 times, insert hook in next dc, draw up loop, skip sc, insert hook in next dc, draw up loop, yo, draw through all 3 loops on hook—dec made, *ch 2, [dc in next dc, ch 2] 3 times, dec; rep from * 13 (13, 14, 14) more times, [ch 2, dc in next dc] 4 times, sc in last st—15 (15, 16, 16) dec; 50 (50, 53, 53) dc. Turn.

row 5: Ch 1, sc in first st, sc in next dc, 2 sc in next ch-sp, [(sc, ch 7, sc) in next dc, (sc, ch 7, sc) in next ch-sp] 2 times, (sc, ch 7, sc) in next dc, sc in next ch-sp, *sl st in dec, sc in next ch-sp, [(sc, ch 7, sc) in next dc, (sc, ch 7, sc) in next ch-sp] 2 times, (sc, ch 7, sc) in next dc, sc in next ch-sp; rep from * 14 (14, 15, 15) more times, sc again in same ch-sp, sc in last 2 sts—80 (80, 85, 85) ch-7 loops. Fasten off.

lower edging: With yarn doubled, crochet hook, and RS facing, join yarn at bottom left front corner, sc in each st across lower edge. Fasten off.

Weave in loose ends. Block lightly. ☐

big lacy scarf page 25

●●●○ I'm feeling pretty confident

size it

30" (76 cm) along chain edge and 5½" (14 cm) wide.

gather it

yarn • Black Forest Naturwolle Tone in Tone (100% wool; 110 yd [100 m]/100 g); #317 feld, 2 skeins (used double). Yarn distributed by Muench Yarns. **hook** • Size N/P-15 (10 mm). Adjust hook size if necessary to obtain the correct gauge. **notions** • Tapestry needle.



gauge it

6½ sc = 4" (10 cm) with yarn doubled.

note it

tr2tog: *Yo twice and insert hook in next dc, draw up a loop, [yo and draw a loop through 2 sts on hook] 2 times (2 loops rem on hook); rep from * once (3 loops rem on hook), yo and pull through rem 3 loops.

crochet it

With yarn doubled, ch 50.

row 1: (RS) Sc into 2nd ch from hook, sc into each ch to end—49 sc. Turn.

row 2: Ch 1, sc into first sc, ch 2, skip 2 sc, sc in next sc, *skip 2 sc, 6 dc in next sc, skip 2 sc, sc in next sc, ch 2, skip 2 sc, sc in next sc; rep from * to end—5 dc scallops. Turn.

row 3: Ch 1, sc into first sc, ch 2, *dc in first dc, [ch 1, dc in next dc] 5 times, sc in next ch-2 sp; rep from * to last 2 sc, omitting sc at end of last rep, ch 2, sc in last sc, turn.

row 4: Ch 4 (counts as 1 tr), [tr in next dc, ch 2] 5 times, *tr2tog (see Note It), ch2, [tr in next dc, ch 2] 4 times; rep from * to last dc, work tr in next dc until 2 loops rem on hook, tr in last sc until 3 loops rem on hook, yo and draw through all 3 loops, turn.

row 5: Ch 1, sc in first st, 3 sc in first ch-2 sp, *ch 7, 3 sc in next ch-2 sp; rep from * to last 2 tr, sc in top of beg ch 4. Fasten off.

finish it

Weave in loose ends. ☐

lace-edge skirt page 25

●●●○ I'm feeling pretty confident

size it

34½ (37, 40½, 43)" (87.5 [94, 103, 109] cm) circumference measured ¼ (¼, ¼, ¼)" (11 [11, 12, 12] cm) below top of waistband, and 17½ (17½, 21¼, 21¼)" (44.5 [44.5, 54, 54] cm) long. Skirt is designed to be worn slightly below the waist. Skirt shown measures 37" (94 cm).



gather it

yarn • Black Forest Naturwolle Tone in Tone (100% wool; 110 yd [100 m]/100 g); #316 wald, 5 (5, 6, 7) skeins (used double). Yarn distributed by Muench Yarns. **needles** • Sizes 17 (12.75 mm) and 19 (15 mm): 24" (60 cm) circular (cir). Adjust needle size if necessary to obtain the correct gauge. **notions** • Markers (m); cable needle (cn); tapestry needle; removable markers or safety pins; size N/P-15 (10 mm) crochet hook.

gauge it

6½ sts and 10 rnds = 4" (10 cm) in St st worked in the rnd on larger needle with yarn doubled.

note it

sssk: Slip 3 sts individually knitwise to right needle, insert tip

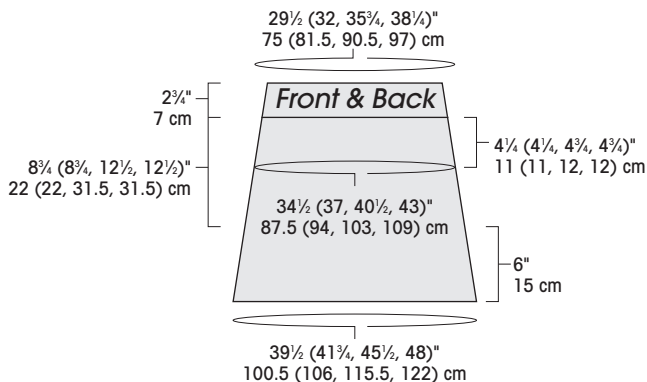

of left needle through the front loops of these 3 sts, then use the right needle to knit them tog through their back loops.

tr2tog: *Yo twice and insert hook in next dc, draw up a loop, [yo and draw a loop through 2 sts on hook] 2 times (2 loops rem on hook); rep from * once (3 loops rem on hook), yo and pull through rem 3 loops.

knit it

With yarn doubled and larger cir needle, CO 64 (68, 74, 78) sts. Place marker (pm) and join for working in the rnd, being careful not to twist sts. Marker denotes right side “seam.” *Next rnd:* K32 (34, 37, 39), pm to denote left side “seam,” k32 (34, 37, 39). Knit 3 (3, 4, 4) rnds. *Decorative rnd:* *K5 (6, 7, 7), M1 (see Know It, page 55), k2, sl 1 st onto cn and hold in front, ssk (see Know It, page 55), k1 from cn, k12 (12, 13, 15), sl 2 sts onto cn and hold in back, k1, k2tog from cn, k2, M1, k5 (6, 7, 7); rep from * to end of rnd. Knit 3 (3, 4, 4) rnds even. Rep the last 4 (4, 5, 5) rnds once more. *Dec rnd:* *K5 (6, 7, 7), M1, k2, sl 1 st onto cn and hold in front, sssk (see Note It), k1 from cn, k10 (10, 11, 13), sl 3 sts onto cn and hold in back, k1, k3tog from cn, k2, M1, k5 (6, 7, 7); rep from * to end of rnd—4 sts dec’d; 60 (64, 70, 74) sts rem. Knit 3 (3, 4, 4) rnds even. Rep decorative rnd, working 10 (10, 11, 13) knit sts at center front and back. Knit 3 (3, 4, 4)

rnds even. *Dec rnd:* *K5 (6, 7, 7), M1, k2, sl 1 st onto cn and hold in front, sssk, k1 from cn, k8 (8, 9, 11), sl 3 sts onto cn and hold in back, k1, k3tog from cn, k2, M1, k5 (6, 7, 7); rep from *—4 sts dec’d; 56 (60, 66, 70) sts rem. Knit 3 (3, 4, 4) rnds even. *Dec rnd:* *K7 (8, 9, 9), sl 1 st onto cn and hold in front, sssk, k1 from cn, k6 (6, 7, 9), sl 3 sts onto cn and hold in back, k1, k3tog from cn, k7 (8, 9, 9); rep from *—8 sts dec’d; 48 (52, 58, 62) sts rem.

waistband: Change to smaller needle. Beg with k1, work k1, p1 rib until band measures 2¾" (7 cm). BO all sts loosely in rib.

finish it

crocheted border: *Note:* Crocheted border is worked on the CO edge (lower body) of the skirt in two sections, each from side “seam” to side “seam.” Place removable markers or safety pins at side seams—32 (34, 37, 39) knitted sts between markers. With skirt upside down, RS facing, and yarn doubled, insert hook in first st after marker and pull through a loop to begin rnd.

rnd 1: Ch 1, *sc in first st, ch 2, skip 1 (1, 1, 2) st(s), sc in next st, skip 2 (2, 1, 1) st(s), dc in next st, 2 dc in each of next 2 sts, dc in next st, skip 2 (2, 1, 1) st(s)*; rep from * to *, ending at marker (between last st of front and first st of back), skipping 0 (2, 2, 0) sts before marker; rep from * to *, beg with first st after marker, ending skip 0 (2, 2, 0) sts before last marker, and working sl st in beg sc to end rnd—6 (6, 8, 8) dc scallops.

rnd 2: Sl st in first ch-2 sp, ch 1, sc in same ch-2 sp, *dc in next dc, [ch 1, dc in next dc] 5 times, sc in ch-2 sp; rep from * around, omitting final sc, sl st in top of beg sc.

rnd 3: Sl st in first dc, ch 6 (counts as tr, ch 2), [tr in next dc, ch 2] 4 times, *tr2tog (see Note It), ch2, [tr in next dc, ch 2] 4 times; rep from * around, tr in last dc, sl st in 4th ch of beg ch-6.

rnd 4: Ch 1, *3 sc in next ch-2 sp, ch 7; rep from *, sl st in top of beg sc. Fasten off.

Weave in loose ends. Block lightly. ☐



fingerless mitts page 28

deborah newton

●●●○ I'm feeling pretty confident

size it

About 8" (20.5 cm) hand circumference and 10" (25.5 cm) long.

gather it

yarn • Filatura di Crosa Aiko (80% cashmere, 20% polyamide; 63 yd [57 m]/25 g): #40 raspberry, 3 balls. Yarn distributed by Tahki/Stacy Charles.

needles • Hand—Size 9 (5.5 mm): straight. Thumb—Size 8 (5 mm): set of 4 double-pointed (dpn). Adjust needle size if necessary to obtain the correct gauge. **notions** • Markers (m); cable needle (cn); tapestry needle.



gauge it

16 sts and 24 rows = 4" (10 cm) in k2, p2 rib on larger needles.

note it

cable panel: (worked over 13 sts)

row 1: (RS) P2, k9, p2.

rows 2, 4, 6, and 8: K2, p9, k2.

row 3: P2, k3, slip 3 sts onto cn and hold in front, k3, k3 from cn, p2.

row 5: P2, k9, p2.

row 7: P2, slip 3 sts onto cn and hold in back, k3, k3 from cn, k3, p2.

Repeat Rows 1–8 for pattern.

k2, p2 ribbing: (multiple of 4 sts + 2)

row 1: (RS) K2, *p2, k2; rep from *.

row 2: P2, *k2, p2; rep from *.

Repeat Rows 1 and 2 for pattern.

knit it

right glove • With larger needles, CO 41 sts. *Set-up row:* (WS) P2, k1, *p1, k1; rep from * to last 2 sts, p2. Cont in rib as established for 2 more rows. *Next row:* (RS) K2, p2, k2, place marker (pm), work cable panel (see Note It) over next 13 sts, pm, work k2, p2 rib to end. Slip markers (sl m) every rnd. Cont in patt as established until piece measures 4" (10 cm) from CO, ending with a WS row.

wrist ribbing: (RS) K2, p2, k2, sl m, cont cable panel as established over 13 sts, sl m, k2, p2, k2, *p1, k1; rep from * to last 4 sts, p2, k2. Cont as established, working k1, p1 rib over 12 wrist sts, cable panel over 13 sts, and k2, p2 rib over rem sts, until k1, p1 rib at wrist measures 2" (5 cm), ending with a WS row.

resume main patt: (RS) K2, p2, k2, sl m, work cable panel over 13 sts, sl m, work k2, p2 rib over rem 22 sts. Cont in patt as established until glove measures 9" (23 cm) from CO, ending with a WS row.

thumb opening: (RS) Keeping in patt as established, work 28 sts, place the last 5 sts worked onto a piece of waste yarn

to be worked later for thumb, work to end. *Next row:* (WS) Keeping in patt, work to thumb gap, use the backward loop method (see Know It, page 54) to CO 5 sts over gap, work to end.

upper hand: Work 4 rows in patt, ending with a WS row. Work in k1, p1 rib for 3 rows. BO all sts.

left glove • Work as for right glove, reversing placement of cable, wrist ribbing, and thumb opening. To reverse placement of cable, work in k2, p2 rib over 22 sts, pm, work cable panel over next 13 sts, pm, k2, p2, k2. To reverse placement of wrist ribbing, k2, p2, *k1, p1; rep from * 5 more times, work in patt as established to end. To reverse thumb opening, keeping in patt as established, work 18 sts, place last 5 sts worked onto a piece of waste yarn to be worked later for thumb, work to end.

finish it

With yarn threaded on a tapestry needle, sew side seam.

thumb: With RS facing, place 5 held thumb sts onto dpn. Join yarn and knit these 5 sts, then pick up and knit 2 sts in corner, with another dpn pick up and knit 5 sts at base of CO sts, with another dpn pick up and knit 2 sts in other corner—14 sts total. Arrange sts as evenly as possible on 3 dpn. Pm and join for working in the rnd. Work in k1, p1 rib until piece measures 1" (2.5 cm) from pick-up. BO all sts.

Weave in loose ends. Block lightly. ☐

crochet slippers page 28

doris chan

●●●● I'm ready for a challenge

See page 93 for instructions.



charm wrap page 28

mary jane mucklestone

●●●● I'm ready for a challenge

size it

36 (40, 44½, 48)" (91.5 [101.5, 113, 122] cm) bust circumference. Sweater shown measures 40" (101.5 cm).

gather it

yarn • Classic Elite Charm (85% cashmere, 15% mohair; 130 yd [119 m]/50 g): #76716 heather ruby, 10 (11, 13, 14) balls.

needles • Sizes 10, 8, and 7 (6, 5, and 4.5 mm): straight. Adjust needle size if necessary to obtain the correct gauge. **notions** • Stitch markers (m); tapestry needle; G/6 (4 mm) crochet hook.



gauge it

17½ sts and 26 rows = 4" (10 cm) in St st on smallest needles.

note it

lace stitch: (multiple of 14 sts + 1)

rows 1, 3, 5, 7, 9, and 11: Purl.

rows 2, 4, 6, 8, 10, and 12: (RS) K1, *yo, k3, ssk, yo, sl 1,

k2tog, pssso, yo, k2tog, k3, yo, k1; rep from *.

row 13: Knit.

row 14: Purl.

Repeat Rows 1–14 for pattern.

knit it

back • With largest needles, loosely CO 85 (99, 113, 127) sts. Change to middle-sized needles. Work Rows 1–14 of lace st (see Note It) 2 times—piece should measure 5" (12.5 cm) from CO. *Next row:* (WS) Change to smallest needles and work even in St st (purl WS rows; knit RS rows) for 13 (7, 7) rows.

shape sides: Dec row: (RS) Dec 1 st each end of needle—2 sts dec'd. Work 9 (5, 7, 5) rows even. Rep the last 10 (6, 8, 6) rows 1 (3, 2, 1) more time(s)—81 (91, 107, 123) sts rem. Rep dec row, then work 7 (3, 5, 3) rows even. Rep the last 8 (4, 6, 4) rows 1 (6, 3, 11) more time(s)—77 (77, 99, 99) sts rem. Rep dec row every 6th (2nd, 4th, 2nd) row 2 (2, 3, 3) times—73 (73, 93, 93) sts rem. Knit 14 (6, 20, 8) rows even, ending with a WS row—piece measures about 16½ (15½, 18½, 17½)" (42 [39.5, 47, 44.5] cm) from CO. *Inc row:* K1, M1 (see Know It, page 55), knit to last st, M1, k1—2 sts inc'd. Work 5 rows even. Rep the last 6 rows 2 (0, 1, 0) more time(s). Rep inc row every 4th row 0 (4, 0, 3) times, then every 2nd row 0 (2, 0, 2) times—79 (87, 97, 105) sts. Work even in St st until piece measures 20½ (21, 21½, 22)" (52 [53.5, 54.5, 56] cm) from CO, ending with a WS row.

shape armholes: BO 3 (4, 4, 4) sts at beg of next 2 rows—73 (79, 89, 97) sts rem. Dec 1 st each end of needle every RS row 2 (3, 3, 3) times—69 (73, 83, 91) sts rem. Cont even in

St st until armholes measure 8 (8½, 9½, 10)" (20.5 [21.5, 24, 25.5] cm), ending with a WS row.

shape shoulders: (RS) Mark center 27 (27, 29, 33) sts. BO 5 (6, 7, 7) sts, knit to marked sts, join a second ball of yarn and BO center 27 (27, 29, 33) sts, knit to end of row. *Next row:* BO 5 (6, 7, 7) sts at beg of first group of sts, work even to end of second group of sts—16 (17, 20, 22) sts rem each side. Working each side separately, at each neck edge, BO 3 (3, 3, 4) sts 2 times, and *at the same time*, at each armhole edge, BO 10 (11, 14, 14) sts once.

left front • With largest needles, loosely CO 50 (64, 64, 78) sts. Change to middle-sized needles. *Set-up row:* (WS) P2, [k1, p1] 2 times, k1, place marker (pm) for end of placket, work Row 1 of lace patt to end of row. Cont as established, working 7 sts in rib for placket and working rem sts in lace patt through Row 14 of lace patt, then work Rows 1–14 again—piece measures 5" (12.5 cm) from CO. Change to smallest needles and St st, and keeping placket sts in rib as established, work 13 (7, 7, 7) rows, ending with a WS row.

shape side: Dec row: (RS) Dec 1 st at beg of row, work as established to end. Work 9 (5, 7, 5) rows even as established. Rep the last 10 (6, 8, 6) rows 1 (3, 2, 1) more time(s)—48 (60, 61, 76) sts rem. Rep dec row, then work 7 (3, 5, 3) rows even. Rep the last 8 (4, 6, 4) rows 1 (6, 3, 11) more time(s)—46 (53, 57, 64) sts rem. Rep dec row, then work 5 (1, 3, 1) row(s) even. Rep the last 6 (2, 4, 2) rows 1 (1, 2, 2) more time(s)—44 (51, 54, 61) sts rem. Work 12 (6, 18, 6) rows even as established, ending with a WS row—piece measures about 16¼ (15½, 18, 17¼)" (41.5 [39.5, 45.5, 44] cm) from CO.

shape neck and side: (RS) Keeping in patt, k1, M1, work to last 3 sts before marker, k2tog, k1, slip marker (sl m), work to end of row—1 st inc'd and 1 st dec'd. Dec 1 st at neck edge and inc 1 st at side edge in this manner every 6th (4th, 6th, 4th) row 2 (6, 1, 5) more time(s)—still 44 (51, 54, 61) sts. Cont to dec 1 st at neck edge *only* every 6th (4th, 6th, 4th) row 1 more time—43 (50, 53, 60) sts rem. Work even until

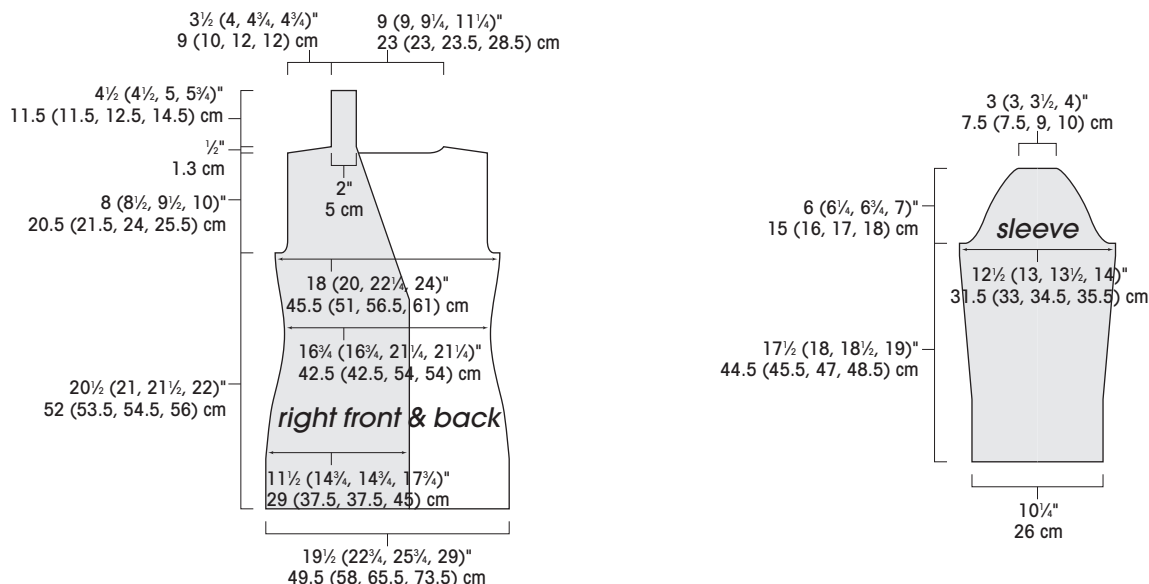

piece measures same as back to armhole, ending with a WS row.

shape armhole: At armhole edge (beg of RS rows), BO 3 (4, 4, 4) sts once, then dec 1 st every RS row 2 (3, 3, 3) times. *At the same time* dec 1 st at neck edge every RS row 14 (17, 16, 23) times—24 (26, 30, 30) sts rem. Work even until piece measures same as back to shoulder.

shape shoulder: At armhole edge (beg of RS rows) BO 5 (6, 7, 7) sts once, then BO 10 (11, 14, 14) sts once—9 sts rem. Cont in rib as established for 30 (30, 32, 38) more rows for neckband extension. BO all sts.

right front • With largest needles, loosely CO 50 (64, 64, 78) sts. Change to middle-sized needles. *Set-up row:* (WS) Work Row 1 of lace patt, pm for placket, [k1, p1] 3 times, p1. Cont as established, working 7 sts in rib for placket and working rem sts in lace patt through Row 14 of lace patt, then work Rows 1–14 again—piece measures 5" (12.5 cm) from CO. Change to smallest needles and St st, and keeping placket sts in rib as established, work 13 (7, 7, 7) rows, ending with a WS row.

shape side: *Dec row:* (RS) Work as established to last 3 sts, dec 1 st, k1. Work 9 (5, 7, 5) rows even as established. Rep the last 10 (6, 8, 6) rows 1 (3, 2, 1) more time(s)—48 (60, 61, 76) sts rem. Rep dec row, then work 7 (3, 5, 3) rows even. Rep the last 8 (4, 6, 4) rows 1 (6, 3, 11) more time(s)—46 (53, 57, 64) sts rem. Rep dec row, then work 5 (1, 3, 1) row(s) even. Rep the last 6 (2, 4, 2) rows 1 (1, 2, 2) more time(s)—44 (51, 54, 61) sts rem. Work 12 (6, 18, 6) rows even as established, ending with a WS row—piece measures about 16¼ (15½, 18, 17¼)" (41.5 [39.5, 45.5, 44] cm) from CO.

shape neck and side: (RS) Keeping in patt, work to marker, sl m, k1, ssk (see Know It, page 55), work to last st, M1, k1—1 st dec'd and 1 st inc'd. Dec 1 st at neck edge and inc 1 st at side edge in this manner every 6th (4th, 6th, 4th) row 2 (6, 1, 5) more time(s)—still 44 (51, 54, 61) sts. Cont to dec 1 st at neck edge *only* every 6th (4th, 6th, 4th) row 1 more time—43 (50, 53, 60) sts rem. Work even until piece measures same as back to armhole, ending with a RS row.

shape armhole: At armhole edge (beg of WS rows) BO 3 (4, 4, 4) sts once, then dec 1 st every RS row 2 (3, 3, 3) times. *At the same time* dec 1 st at neck edge every RS row 14 (17, 16, 23) times—24 (26, 30, 30) sts rem. Work even until piece measures same as back to shoulder.

shape shoulder: At armhole edge (beg of WS rows) BO 5 (6, 7, 7) sts once, then BO 10 (11, 14, 14) sts once—9 sts rem. Cont in rib as established for 30 (30, 32, 38) more rows for neckband extension. BO all sts.

sleeves • (make 2) With largest needles, CO 45 sts. Change to middle-sized needles. *Next row:* Working first and last st in St st for edge sts, work center 43 sts according to Row 1 of lace patt. Cont as established, work through Row 14 of lace patt, then work Rows 1–14 again. Change to smallest needles and St st and inc 1 st each end of needle every 8th row 5 (6, 7, 8) times—55 (57, 59, 61) sts. Cont even until piece measures 17½ (18, 18½, 19)" (44.5 [45.5, 47, 48.5] cm) from CO, ending with a WS row.

shape cap: BO 3 (4, 4, 4) sts at beg of next 2 rows, then BO 2 sts at beg of foll 2 rows—45 (45, 47, 49) sts rem. Dec 1 st each end of needle every row 7 (5, 4, 4) times—31 (35, 39,

41) sts rem. Dec 1 st each end of needle every 4th row 5 (5, 6, 7) times—21 (25, 27, 27) sts rem. Dec 1 st each end of needle every other row 4 (6, 6, 5) times—13 (13, 15, 17) sts rem. BO all sts.

belt • With smallest needles, CO 17 sts. *Set-up row:* K2, [p1, k1] 7 times, k1. Work in rib patt as established until piece measures 58 (62, 66, 70)" (147.5 [157.5, 167.5, 178] cm) from CO. BO all sts.

finish it

Weave in loose ends. Block to measurements. With yarn threaded on a tapestry needle, sew fronts to back at shoulders. Sew neckband extensions to back neck. Sew neckband seam. Sew sleeve caps into armholes. Sew sleeve and side seams, matching purl bands in lace st patt. Steam-block lightly.

belt loops: (make 2) With crochet hook, make a chain (see Know It, page 57) about 4" (10 cm) long. Sew one chain to each side seam at waistline. ☐

flared skirt page 29

●●○○ I'm ready to move past scarves

size it

32 (36, 40)" (81.5 [91.5, 101.5] cm) circumference. Finished size should measure an inch or two smaller than actual hip size. Skirt shown measures 32" (81.5 cm).

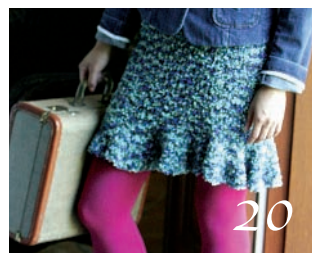

gather it

yarn • Muench Fabu (90% viscose, 10% polyester; 79 yd [72 m]/50 g): #M4301 ribera (lime/olive/blue mix), 5 (6, 6) balls. **needles** • Size 10 (6 mm). Adjust needle size if necessary to obtain the correct gauge. **notions** • Tapestry needle; 1" (2.5-cm) wide skirt elastic, about 1" (2.5 cm) longer than waist circumference; sharp-point sewing needle and thread.

gauge it

14 sts and 24 rows = 4" (10 cm) in St st. *Note:* The sts are difficult to see in this yarn; to work a gauge swatch, cast on 14 sts and work for 24 rows. Finished swatch should measure 4" (10 cm) square.

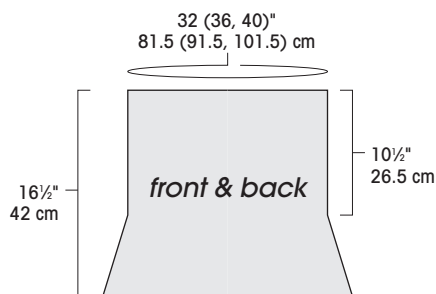

note it

Skirt is worked sideways in one piece from center back to center back. The flounce is made by working short-rows (see Know It, page 56) at the hem edge.

knit it

skirt • CO 58 sts. Beg with a RS row, work 4 rows in St st (knit RS rows; purl WS rows). Work 14 short-rows (see Know It, page 56) to form flounce on first 21 sts, followed by 8 rows across all sts as foll:

short-rows 1 and 2: K3, turn work around, sl 1 purlwise, p2. short-rows 3 and 4: K6, turn, sl 1 purlwise, p5.

short-rows 5 and 6: K9, turn, sl 1 purlwise, p8.

short-rows 7 and 8: K12, turn, sl 1 purlwise, p11.

short-rows 9 and 10: K15, turn, sl 1 purlwise, p14.

short-rows 11 and 12: K18, turn, sl 1 purlwise, p17.

short-rows 13 and 14: K21, turn, sl 1 purlwise, p20.

row 15: (RS) K58 to end.

rows 16–22: Work even in St st (7 rows).

Rep these 22 rows until piece measures 32 (36, 40)" (81.5 [91.5, 101.5] cm) from CO, or desired circumference, ending with Row 18 (2nd purl row of a St st section). With RS facing, BO all sts.

finish it

With yarn threaded on a tapestry needle, loosely sew CO edge to BO edge for center back seam. Fold over 1½" (3.8 cm) along non-flared edge and sew in place for waistband, leaving a short opening for threading elastic. Cut elastic to 1" (2.5 cm) longer than waist circumference. Thread elastic through waistband opening, overlap ends by 1" (2.5 cm), and with sharp-point sewing needle and thread, sew ends tog. Weave in loose ends. □

silk cardigan page 30

norah gaughan

●●●○ I'm feeling pretty confident

size it

34½ (38, 42, 46, 49½)" (87.5 [96.5, 106.5, 117, 125.5] cm) bust/chest circumference. Sweater shown measures 38" (96.5 cm).



gather it

yarn • Muench Sir Galli (100% silk; 114 yd [104 m]/50 g): #4907 beige multicolor tweed, 9 (9, 10, 11, 12) balls.

needles • Body and sleeves—Size 8 (5 mm). Ribbing—Size 6 (4 mm). Adjust needle size if necessary to obtain the correct gauge. **notions** • Markers (m); tapestry needle; size H/8 (5 mm) crochet hook; five 1½" (3.8-cm) buttons.

gauge it

16 sts and 21 rows = 4" (10 cm) in St st on larger needles; 17 sts and 21 rows = 4" (10 cm) in pattern st on larger needles.

note it

k1, p1 rib: (even number of sts)
all rows: *K1, p1; rep from * to end.

pattern stitch: (multiple of 2 sts + 1)

row 1: (RS) *P1, k1; rep from * to last st, p1.

row 2: Purl.

Repeat Rows 1 and 2 for pattern.

knit it

back • With smaller needles, CO 70 (78, 86, 94, 102) sts. Work in k1, p1 rib (see Note It) until piece measures 3" (7.5 cm) from CO, ending with a WS row, and inc 1 st at end of last row—71 (79, 87, 95, 103) sts. **Next row:** (RS) Change to larger needles and set up patt as foll: K14 (16, 18, 20, 22), place marker (pm), work 43 (47, 51, 55, 59) center sts in patt st (see Note It), pm, k14 (16, 18, 20, 22). Cont as established, working first and last 14 (16, 18, 20, 22) sts in St st and center 43 (47, 51, 55, 59) sts in patt st, until piece measures 12" (30.5 cm) from CO, ending with a WS row.

shape armholes: Cont in patt, BO 4 sts at beg of next 0 (0, 2, 2, 4) rows, then BO 3 sts at beg of foll 2 rows, then BO 2 sts at beg of foll 2 (4, 2, 4, 2) rows—61 (65, 69, 73, 77) sts rem. **Next row:** (RS) K3, k2tog, knit to last 5 sts, ssk (see Know It, page 55), k3—2 sts dec'd. Work 1 WS row even. Rep the last 2 rows 2 more times—55 (59, 63, 67, 71) sts rem. Cont even in patt until armholes measure 7 (7½, 8, 8½, 9)" (18 [19, 20.5, 21.5, 23] cm), ending with a WS row.

shape neck and shoulders: Mark center 9 (11, 11, 13, 13) sts. With RS facing, BO 5 (6, 6, 7, 7) sts, work to first marker, join a new ball of yarn and BO center 9 (11, 11, 13, 13) sts, work to end of row. **Next row:** (WS) BO 5 (6, 6, 7, 7) sts, work to end of first group of sts, work even across second group of sts—18 (18, 20, 20, 22) sts rem at each side. Working each side separately, at each neck edge, BO 4 sts 2 times, and *at the same time*, at each armhole edge, BO 5 (5, 6, 6, 7) sts 2 times.

left front • With smaller needles, CO 34 (38, 42, 46, 50) sts. Work k1, p1 rib until piece measures 3" (7.5 cm) from CO, ending with a WS row, and inc 1 st at end of last row—35 (39, 43, 47, 51) sts. **Next row:** (RS) Change to larger needles and set up patt as foll: K14 (16, 18, 20, 22), pm, work 21 (23, 25, 27, 29) sts in patt st. Cont in established patt until piece measure 12" (30.5 cm) from CO, ending with a WS row.

shape armhole: Cont in patt, at armhole edge (beg of RS rows) BO 4 sts 0 (0, 1, 1, 2) time(s), then BO 3 sts 1 time, then BO 2 sts 1 (2, 1, 2, 1) time(s)—30 (32, 34, 36, 38) sts rem. **Next row:** (RS) K3, k2tog, knit to end—1 st dec'd. Work 1 WS row even. Rep the last 2 rows 2 more times—27 (29, 31, 33, 35) sts rem. Cont even in patt until armhole measures 5 (5½, 6, 6½, 7)" (12.5 [14, 15, 16.5, 18] cm), ending with a RS row.

shape neck and shoulders: Cont in patt, at neck edge (beg of WS rows) BO 4 sts once, then BO 3 sts once, then BO 2 sts 2 times—16 (18, 20, 22, 24) sts rem; piece measures about 1½" (3.8 cm) from beg of neck shaping. **Note:** Shoulder shaping begs before neck shaping is completed for some sizes; read

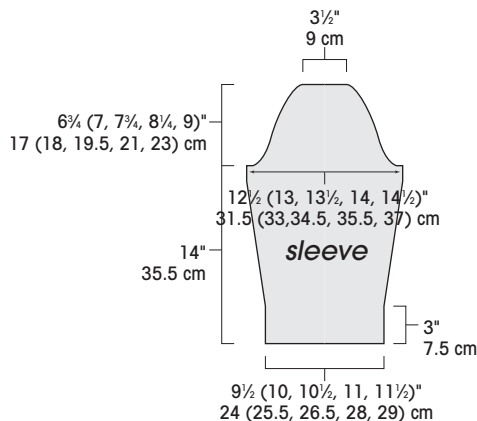
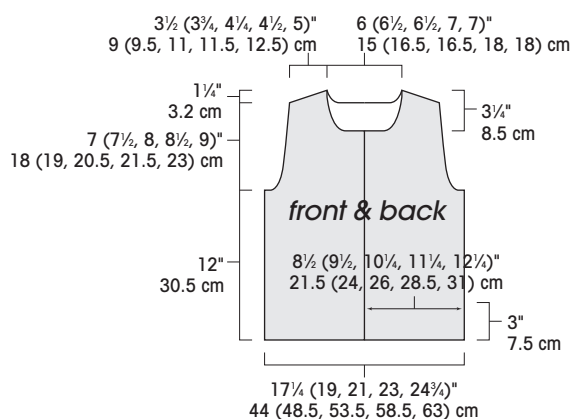

the next section all the way through before proceeding. *Next RS row:* Work in patt to last 5 sts, ssk, k3—1 st dec'd. Work 1 WS row even. Rep the last 2 rows 0 (1, 1, 2, 2) more times, and *at the same time*, when armhole measures 7 (7 1/2, 8, 8 1/2, 9)" (18 [19, 20.5, 21.5, 23] cm), at armhole edge (beg of RS rows) BO 5 (6, 6, 7, 7) sts once, then BO 5 (5, 6, 6, 7) sts 2 times.

right front • With smaller needles, CO 34 (38, 42, 46, 50) sts. Work k1, p1 rib until piece measures 3" (7.5 cm) from CO, ending with a WS row, and inc 1 st at end of last row—35 (39, 43, 47, 51) sts. *Next row:* (RS) Change to larger needles and set up patt as foll: Work 21 (23, 25, 27, 29) sts in patt st, pm, k14 (16, 18, 20, 22). Cont in established patt until piece measure 12" (30.5 cm) from CO, ending with a RS row.

shape armhole: Cont in patt, at armhole edge (beg of WS rows) BO 4 sts 0 (0, 1, 1, 2) time(s), then BO 3 sts 1 time, then BO 2 sts 1 (2, 1, 2, 1) time(s)—30 (32, 34, 36, 38) sts rem. *Next RS row:* Knit to last 5 sts, ssk, k3—1 st dec'd. Work 1 WS row even. Rep the last 2 rows 2 more times—27 (29, 31, 33, 35) sts rem. Cont even in patt until armhole measures 5 (5 1/2, 6, 6 1/2, 7)" (12.5 [14, 15, 16.5, 18] cm), ending with a WS row.

shape neck and shoulders: Cont in patt, at neck edge (beg of RS rows) BO 4 sts once, then BO 3 sts once, then BO 2 sts 2 times—16 (18, 20, 22, 24) sts rem; piece measures about 1 1/2" (3.8 cm) from beg of neck shaping. *Note:* Shoulder shaping begs before neck shaping is completed for some sizes; read the next section all the way through before proceeding. *Next RS row:* K3, k2tog, work in patt to end—1 st dec'd. Work 1 WS row even. Rep the last 2 rows 0 (1, 1, 2, 2) more time(s), and *at the same time*, when armhole measures 7 (7 1/2, 8, 8 1/2, 9)" (18 [19, 20.5, 21.5, 23] cm), at armhole edge (beg of WS rows) BO 5 (6, 6, 7, 7) sts once, then BO 5 (5, 6, 6, 7) sts 2 times.

sleeves • With smaller needles, CO 38 (40, 42, 44, 46) sts. Work k1, p1 rib until piece measures 3" (7.5 cm) from CO, ending with a WS row, and inc 1 st at end of last row—39 (41, 43, 45, 47) sts. *Next row:* (RS) Change to larger needles and set up patt as foll: K9, pm, work 21 (23, 25, 27, 29) sts in patt

st, pm, k9. Cont in patt as established, working first and last 9 sts in St st and center 21 (23, 25, 27, 29) sts in patt st, until piece measures 4" (10 cm) from CO, ending with a WS row. *Next row:* (RS) K2, M1 (see Know It, page 55), work in patt to last 2 sts, M1, k2—2 sts inc'd. Work 9 rows even in patt. Rep the last 10 rows 4 more times, then work inc row once more, working inc'd sts in St st—51 (53, 55, 57, 59) sts. Cont even in patt until piece measures 14" (35.5 cm) from CO, ending with a WS row.

shape cap: Cont in patt, BO 3 sts at beg of next 2 rows, then BO 2 sts at beg of foll 2 rows—41 (43, 45, 47, 49) sts rem. *Dec row:* (RS) K3, k2tog, work to last 5 sts, ssk, k3—2 sts dec'd. Dec 1 st each end of needle in this manner every RS row 0 (1, 1, 1, 1) more time, then every 4th row 6 (6, 7, 7, 8) times, then every RS row 1 (1, 1, 2, 2) time(s)—25 sts rem for all sizes. BO 2 sts at beg of next 2 rows, then BO 3 sts at beg of foll 2 rows—15 sts rem. BO all sts.

finish it

left front band: With smaller needles and RS facing, pick up and knit 74 (76, 78, 80, 82) sts along left front edge. Work k1, p1 rib until band measures 2" (5 cm). BO all sts.

right front band: Mark placement of 5 buttonholes on right front, one 1 1/2" (3.8 cm) down from neck edge, one 1 1/2" (3.8 cm) up from bottom edge, and the other 3 evenly spaced in between. With smaller needles and RS facing, pick up and knit 74 (76, 78, 80, 82) sts along right front edge. Work k1, p1 rib until band measures 1" (2.5 cm), ending with a WS row.

Buttonhole row: (RS) Cont in rib, BO 3 sts at each marked buttonhole position. *Next row:* Cont in rib, use the backward loop method (see Know It, page 54) to CO 3 sts over each gap to complete buttonholes. Cont in rib until band measures 2" (5 cm). BO all sts.

neckband: With yarn threaded on a tapestry needle, sew fronts to back at shoulders. With crochet hook and RS facing, work 1 row of single crochet (sc; see Know It, page 57, for crochet instructions) around neck edge, turn. Cont as foll:
row 1: Ch 3, dc in 2nd sc, *ch 1, skip 1 sc, dc in next sc; rep from * to end, turn.

row 2: Ch 1, *(slip st 1, ch 3, slip st 1) all in same ch-1 space; rep from * to end.

Fasten off.

I-cord waist drawstring (optional): With smaller needles, CO 3 sts. *K3, return the 3 sts just worked to left needle with RS still facing, pull yarn taut across back of work; rep from * until piece measures 54½ (58, 62, 66, 69½)" (138.5 [147.5, 157.5, 167.5, 176.5] cm) from CO. K3tog, break yarn, and fasten off last st.

With yarn threaded on a tapestry needle, sew sleeve caps into armholes. Sew sleeve and side seams. Weave in loose ends. Sew buttons to left front band, opposite buttonholes. Try on sweater to determine height of waistline or desired location of optional I-cord drawstring. Thread drawstring through the sweater body, going in and out about 1" (2.5 cm) apart, and beg and ending at edge of front bands. Block lightly. ☐

twin set page 31

sharon shoji

●●●○ I'm feeling pretty confident

on the web knitscene.com

size it

Tank—32½ (36, 40, 44, 47½)" (82.5 [91.5, 101.5, 112, 120.5] cm) bust circumference. Tank shown measures 32½" (82.5 cm). Shrug—34½ (38½, 42½, 46½, 50½)" (87.5 [98, 108, 118, 128.5] cm) bust circumference. Shrug shown measures 34½" (87.5 cm).

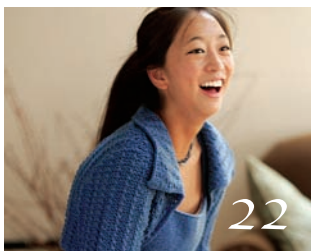

gather it

yarn • Tank—Classic Elite Princess (40% merino, 28% viscose, 15% nylon, 10% cashmere, 7% angora; 150 yd [137 m]/50 g): #3457 blue blood, 3 (4, 4, 5, 5) skeins. Shrug—Classic Elite Duchess (40% merino, 28% viscose, 15% nylon, 10% cashmere, 7% angora; 75 yd [69 m]/50 g): #1057 blue blood, 6 (7, 8, 9, 9) skeins. Small amount of Princess yarn in matching color for sewing seams and edging; purchase 1 skein of Princess if not using leftovers from tank. ☐

flower afghan page 32

ann regis

●●●○ I'm feeling pretty confident

on the web knitscene.com

size it

37" (94 cm) square.

gather it

yarn • Filatura di Crosa Zara (100% superwash merino



wool; 137 yd [125 m]/50 g): #1461 burgundy (MC), 9 balls; #1525 brick, 3 balls; #1722 purple, 2 balls; #1503 olive, #1666 fuchsia, and #1718 tangerine, 1 ball each. ☐

kid's slippers page 32

doris chan

●●●● I'm ready for a challenge

on the web knitscene.com

size it

5 (6, 7)" (12.5 [15, 18] cm) from back of heel to tip of toe. To fit children's U.S. shoe sizes 6 (9, 12). Slippers shown measure 6" (15 cm).



gather it

yarn • Filatura di Crosa Zara (100% superwash merino wool; 137 yd [125 m]/50 g): #1722 purple (A), #1392 pink (B), #1466 red (C), and 1 ball each. ☐

sabrina tam page 32

●●○○ I'm ready to move past scarves

size it

20" (51 cm) circumference, relaxed. Will stretch to 22" (56 cm) circumference.

gather it

yarn • Stacy Charles Sabrina (45% wool, 25% cotton, 15% viscose, 10% acrylic, 5% polyamide; 60 yd [55 m]/50 g) # 26 plum/pink/gold/blue mix, 2 balls. Yarn distributed by Tahki/Stacy Charles. needles • Size 10 (6 mm): set of 4 double-pointed (dnp) and 16" (40 cm) circular (cir). Adjust needle size if necessary to obtain the correct gauge. notions • Markers (m); tapestry needle.



gauge it

12 sts and 15 rows = 4" (10 cm) in St st worked in the rnd.

note it

The tam is worked in the round from the center of the crown to the outer edge. Begin by working on double-pointed needles, and switch to a circular needle when the hat circumference is large enough.

You may find it helpful to use markers between the six sections. This project uses yarnover (yo) increases for shaping. On the first round, work the yarnover as usual. On the following round, work each yarnover through its back loop to reduce the size of the hole. The texture of the yarn will disguise the holes.

knit it

With dnp, CO 6 sts. Divide sts onto 3 dnp, with 2 sts on each

dpn. Place marker (pm) and join for working in the rnd, being careful not to twist sts. Work as foll:

rnds 1, 3, and 5: Knit.

rnd 2: *K1, yo; rep from *—12 sts.

rnd 4: *K2, yo; rep from *—18 sts.

rnd 6: *K3, yo; rep from *—24 sts.

Cont in this manner, working 1 more st before making a yo in each inc rnd, and working 1 rnd even between inc rnds, until you've worked a rnd of k12, yo—78 sts; 13 sts each in 6 sections. Work even in St st until piece measures about 6½" (16.5 cm) from center of crown, measured straight along a single column of sts from CO to needles. Cont as foll:

rnd 1: *K11, k2tog; rep from *—72 sts rem.

rnds 2, 4, and 6: Knit.

rnd 3: *K10, k2tog; rep from *—66 sts rem.

rnd 5: *K9, k2tog; rep from *—60 sts rem.

rnds 6–9: *K1, p1; rep from * to end.

BO all sts in rib.

finish it

Weave in loose ends. 

ribbon wrap page 33

●●●○ I'm feeling pretty confident

size it

32 (36, 40, 44½, 48½)" (81.5 [91.5, 101.5, 113, 123] cm) bust circumference, tied. Sweater shown measures 36" (91.5 cm).

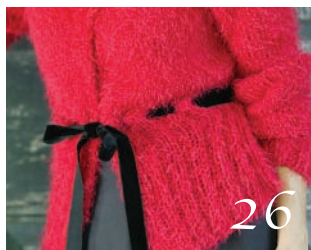

gather it

yarn • Stacy Charles Micio (60% polyamide, 40% wool; 110 yd [100 m]/50 g): #4 red, 6 (7, 8, 9, 10) balls. Yarn distributed by Tahki/Stacy Charles. **needles** • Sizes 10½ and 11 (6.5 and 8 mm). Adjust needle size if necessary to obtain the correct gauge. **notions** • 2 (2, 2½, 2½, 2¾) yd (2 [2, 2, 2.25, 2.5] m) black velvet ribbon 1" (2.5-mm) wide; tapestry needle.

gauge it

15½ sts and 20 rows = 4" (10 cm) in St st on smaller needles.

knit it

back • With larger needles, CO 58 (66, 74, 82, 90) sts.

row 1: (RS) *K2, p2; rep from * to last 2 sts, k2.

row 2: *P2, k2; rep from * to last 2 sts, p2.

Cont in rib as established until piece measures 5" (12.5 cm) from CO, ending with a WS row. Change to smaller needles and cont in rib patt until piece measures 7 (7, 7, 8, 8)" (18 [18, 18, 20.5, 20.5] cm) from CO, ending with a WS row. *Eyelet row:* (RS) K2, *yo, p2tog, k2; rep from * to end of row—14 (16, 18, 20, 22) eyelets made. *Next row:* Purl across all sts. Work 6 more rows in St st (knit RS rows; purl WS rows)—8 rows total in St st, including eyelet row; piece measures about 8½ (8½, 8½, 9½, 9½)" (21.5 [21.5, 21.5, 24, 24] cm) from CO. *Inc row:* (RS) K2, M1 (see Know It, page 55), knit to last 2 sts, M1, k2—2 sts inc'd. Work in St st for 9 more rows, end-

ing with a WS row, then rep inc row once more—62 (70, 78, 86, 94) sts. Cont even in St st until piece measures 13½ (13½, 14½, 14½, 15)" (34.5 [34.5, 37, 37, 38] cm) from CO, ending with a WS row.

shape armholes: BO 4 sts at beg of next 2 rows, then BO 2 sts at beg of foll 2 rows—50 (58, 66, 74, 82) sts rem. Dec 1 st each end of needle every RS row 0 (2, 2, 4, 6) times—50 (54, 62, 66, 70) sts rem. Cont even in St st until armholes measure 6¾ (7¼, 7½, 8, 8½)" (17 [18.5, 19, 20.5, 21.5] cm), ending with a WS row.

shape neck and shoulders: (RS) K11 (12, 15, 16, 17), join a second ball of yarn and BO center 28 (30, 32, 34, 36) sts, knit to end—11 (12, 15, 16, 17) sts rem each side. Working each side separately, BO 3 (3, 3, 3, 4) sts at each neck edge once, and BO at each armhole edge 4 (4, 6, 6, 6) sts once, then BO 4 (5, 6, 7, 7) sts once.

right front • With larger needles, CO 29 (33, 37, 41, 45) sts. row 1: (RS) Sl 1 as if to knit, *k2, p2; rep from * to end of row. row 2: *K2, p2; rep from * to last 5 sts, k2, p3.

Rep Rows 1 and 2 until piece measures 5" (12.5 cm) from CO, ending with a WS row. Change to smaller needles and cont in rib patt until piece measures 7 (7, 7, 8, 8)" (18 [18, 18, 20.5, 20.5] cm) from CO, ending with a WS row. *Eyelet row:* (RS) Sl 1, k2, *yo, p2tog, k2; rep from * to last 2 sts, p2—6

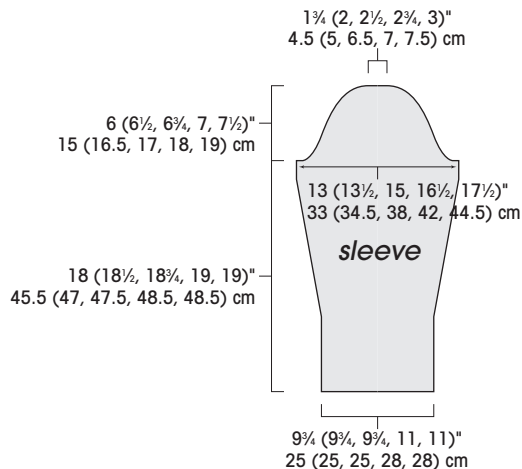
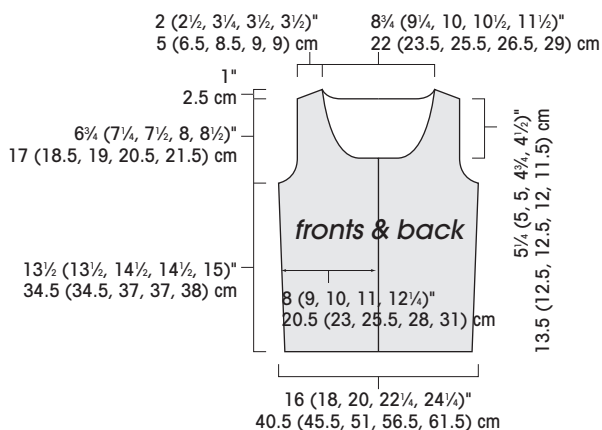

(7, 8, 9, 10) eyelets made. *Next WS row:* Purl to last 5 sts, k2, p3. *Next RS row:* Sl 1 as if to knit, k2, p2, knit to end. Rep the last 2 rows 2 more times, then work WS row once more—8 rows total in St st, including eyelet row; piece measures about 8½ (8½, 8½, 9½, 9½)" (21.5 [21.5, 21.5, 24, 24] cm) from CO. *Inc row:* (RS) Cont in patt as established to last 2 sts, M1, k2—1 st inc'd. Work even in patt for 9 more rows, ending with a WS row, then rep inc row once more—31 (35, 39, 43, 47) sts. Cont even in St st until piece measures same as back to armhole, ending with a RS row.

shape armhole: BO 4 sts at beg of next WS row, then BO 2 sts at beg of foll WS row—25 (29, 33, 37, 41) sts rem. Dec 1 st at armhole edge (end of RS rows) on the next 0 (2, 2, 4, 6) RS rows—25 (27, 31, 33, 35) sts rem. Work even in patt, if necessary for your size, until armhole measures about ¾ (1½, 1¾, 2½, 3¼)" (2 [3.8, 4.5, 6.5, 8.5] cm), ending with a WS row. *Eyelet row:* (RS) Sl 1 as if to knit, k2, yo, p2tog, knit to end of row—1 eyelet formed at front opening for all sizes. Work 3 rows even in established patt, ending with a WS row.

shape neck: At neck edge (beg of RS rows) BO 7 (8, 9, 10, 12) sts once, then BO 3 sts once, then BO 2 sts once—13 (14, 17, 18, 18) sts rem. Dec 1 st at beg of every RS row 2 times, then dec 1 st at beg of every other RS row 3 times—8 (9, 12, 13, 13) sts rem. Work even in St st until armhole measures 6¼ (7¼, 7½, 8, 8½)" (17 [18.5, 19, 20.5, 21.5] cm), ending with a RS row.

shape shoulder: BO 4 (4, 6, 6, 6) sts at beg of next WS row, then BO 4 (5, 6, 7, 7) sts at beg of foll WS row.

left front • With larger needles, CO 29 (33, 37, 41, 45) sts. *row 1:* (RS) *P2, k2; rep from * to last 5 sts, p2, k3. *row 2:* Sl 1 st as if to purl, p1, k2, *p2, k2; rep from * to end. Rep Rows 1 and 2 until piece measures 5" (12.5 cm) from CO, ending with a WS row. Change to smaller needles and cont in rib patt until piece measures 7 (7, 7, 8, 8)" (18 [18, 18, 20.5, 20.5] cm) from CO, ending with a WS row. *Eyelet row:* (RS) K4, *yo, p2tog, k2; rep from * to last st, end k1—6 (7, 8, 9, 10) eyelets made. *Next WS row:* Sl 1 as if to purl, p1, k2, purl to end. *Next RS row:* Knit to last 5 sts, p2, k3. Rep the last 2 rows 2 more times, then work WS row once more—8 rows total in St st, including eyelet row; piece measures about 8½ (8½, 8½, 9½, 9½)" (21.5 [21.5, 21.5, 24, 24] cm) from CO. *Inc row:* (RS) K1, M1, work in established patt to end—1 st inc'd. Work even in patt for 9 more rows, ending with a WS row, then rep inc row once more—31 (35, 39, 43, 47) sts. Cont even in St st until piece measures same as back to armhole, ending with a WS row.

shape armhole: BO 4 sts at beg of next RS row, then BO 2 sts at beg of foll RS row—25 (29, 33, 37, 41) sts rem. Dec 1 st at armhole edge (beg of RS rows) on the next 0 (2, 2, 4, 6) RS rows—25 (27, 31, 33, 35) sts rem. Work even in patt, if necessary for your size, until armhole measures about ¾ (1½, 1¾, 2½, 3¼)" (2 [3.8, 4.5, 6.5, 8.5] cm), ending with a WS row. *Eyelet row:* (RS) Knit to last 5 sts, yo, p2tog, k3—1 eyelet formed at front opening for all sizes. Work 4 rows even in established patt, ending with a RS row—armhole measures about 1½ (2¼, 2½, 3¼, 4)" (3.8 [5.5, 6.5, 8.5, 10] cm).

shape neck and shoulder: Work as for right front, reversing shaping by binding off for neck at beg of WS rows, dec for neck at end of RS rows, and binding off for shoulder at beg of RS rows.

sleeves • With smaller needles, CO 38 (38, 38, 42, 42) sts. *row 1:* (RS) *K2, p2; rep from * to last 2 sts, k2.

row 2: *P2, k2; rep from * to last 2 sts, p2.

Cont in rib as established until piece measures 5" (12.5 cm) from beg, ending with a WS row. *Work 2 rows even in St st, ending with a WS row.* *Inc row:* (RS) K2, M1, knit to last 2 sts, M1, k2—2 sts inc'd. *Work 9 (9, 7, 5, 5) rows even in St st.* Rep the last 10 (10, 8, 6, 6) rows 2 (2, 1, 8, 3) more time(s)—44 (44, 42, 60, 50) sts. Rep inc row once more, then work 7 (7, 5, 3, 3) rows even. Rep the last 8 (8, 6, 4, 4) rows 2 (3, 7, 1, 8) more time(s)—50 (52, 58, 64, 68) sts. *Work even in St st until piece measures 18 (18½, 18¾, 19, 19)" (45.5 [47, 47.5, 48.5, 48.5] cm) from CO, ending with a WS row.*

shape cap: BO 4 sts at beg of next 2 rows, then BO 2 sts at beg of foll 2 rows—38 (40, 46, 52, 56) sts rem. Dec 1 st each end of needle every RS row 1 time—36 (38, 44, 50, 54) sts rem. *Work even until piece measures 4¼ (4½, 5, 5¼, 5¾)" (11 [11.5, 12.5, 13.5, 14.5] cm) from beg of sleeve cap shaping, ending with a WS row.* Dec 1 st each end of needle on next 4 RS rows, then purl 1 WS row—28 (30, 36, 42, 46) sts rem. *Next row:* (RS) *K2tog; rep from *—14 (15, 18, 21, 23) sts rem. *Next row:* (WS) BO all sts, working p2tog 7 (7, 9, 10, 11) times across BO row, ending p0 (1, 0, 1, 1).

finish it

Gently steam-block pieces to measurements, taking care to not touch iron to surface of pieces or the ends of the fluffy nap. With yarn threaded on a tapestry needle, sew shoulder seams. Align center of sleeve cap with shoulder seam and sew sleeve cap to armhole. Sew sleeve and side seams. Weave in loose ends. Cut a piece of ribbon 52 (58, 66, 74, 82)" (132 [147.5, 167.5, 188, 208.5] cm) long and thread through eyelets at waistline, beg and ending at front opening. Thread rem ribbon through eyelets at neck edge and tie into a bow, if desired. Trim ribbon ends to 45-degree angles. □

bandeau page 34 véronik avery

●●○○ I'm ready to move past scarves

size it

28 (31¼, 34¾, 38, 41¼, 44¾)" (71 [79.5, 88.5, 96.5, 105, 113.5] cm). Bandeau shown measures 31¼" (79.5 cm).



gather it

yarn • Classic Elite Renaissance (100% wool; 110 yd [100 m]/50 g): #7158 red (MC), 4 (4, 5, 5, 6, 6) skeins; #7185 Portifino orange, #7181 green grape, and #7168 Vatican gold, 1 skein each. **needles** • Sizes 5 and 7 (3.75 and 4.5 mm): 24" (60 cm) circular (cir). Adjust needle size if necessary to obtain the correct gauge. **notions** • Marker (m); tapestry needle.

gauge it

24 sts and 26 rnds = 4" (10 cm) in St st color pattern on larger needles.

note it

See page 35 to learn how to knit with two colors.

knit it

body • With MC and smaller needle, CO 168 (188, 208, 228, 248, 268) sts. Place marker (pm) and join for working in the rnd, being careful not to twist sts.

lower ribbing: *K2, p2; rep from * to end of rnd. Cont in k2, p2 rib until piece measures 6¼ (7, 7¼, 7½, 7¾, 8)" (17 [18, 18.5, 19, 19.5, 20.5] cm) from CO. Change to St st and work even for 1 (1, 1¼, 1½, 1½, 1½)" (2.5 [2.5, 3.2, 3.2, 3.8, 3.8] cm) more.

color patt: Change to larger needle and work Rows 1–19 of Fair Isle chart. Change to smaller needle. Knit 4 rnds even. **Next rnd:** Knit, and *at the same time* dec 20 (24, 28, 32, 32, 32) sts evenly spaced—148 (164, 180, 196, 216, 236) sts rem.

upper ribbing: *K2, p2; rep from * to end of rnd. Cont in k2, p2 rib for 1½" (3.8 cm). Loosely BO all sts.

finish it

Weave in loose ends. Block to measurements. ☐

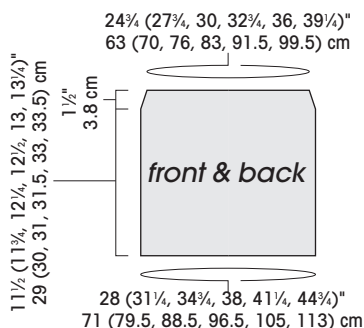
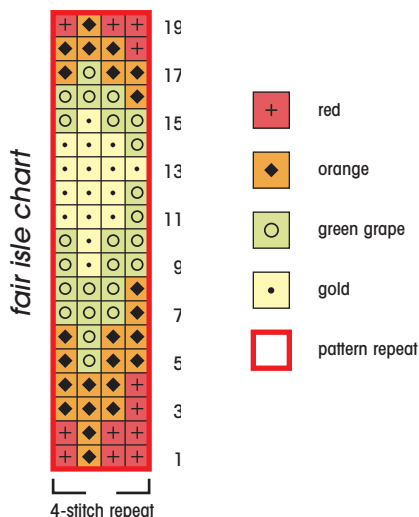

zig zag cardigan page 38

loretta warner

●●●● I'm ready for a challenge

on the web knitscene.com

size it

44" (112 cm) bust
circumference.

gather it

yarn • GGH Esprit (100% polyamide; 87 yd [80 m]/50 g): #20 pink, 8 balls. GGH

Amelie (100% microfiber nylon; 71 yd [65 m]/50 g): #5 raspberry red and #4 vibrant pink, 1 ball each. Yarn distributed by Muench Yarns. ☐



28

cape and tails page 40

loretta warner

●●○○ I'm ready to move past scarves

on the web knitscene.com

size it

33" (84 cm) at neck, 80" (203 cm) at lower edge, and 11½" (29 cm) long.

gather it

yarn • Muench Lucky (98% nylon, 2% polyester; 110 yd [100 m]/50 g): #5014 maize fields, 6 balls. ☐



29

shrug page 40

loretta warner

●●●○ I'm feeling pretty confident

on the web knitscene.com

size it

58" (147.5 cm) wide and 27" (68.5 cm) long.

gather it

yarn • Black Forest Naturwolle Tone in Tone (100% new wool handspun; 110 yd [110 m]/50 g): #136 wald (MC), 4 skeins. Muench Furari Toscana (79% mohair, 19% acrylic, 2% polyester, 76 yd [70 m]/50 g): #M4401 (CC), 3 balls. GGH Insertion (100% polyamide; 87 yd [80 m]/50 g): #4 birthday party and #5 delightful intent, 1 ball each. Yarn distributed by Muench Yarns. ☐



30

●●○○ I'm ready to move past scarves

size it

41¼ (43, 45, 46¾)" (105 [109, 114.5, 118.5] cm) chest circumference. Sweater shown measures 43" (109 cm).



gather it

yarn • Filatura di Crosa 127 Print (100% wool; 93 yd [85 m]/50 g): #18 black with orange/brown/cedar/navy, 11 (12, 13, 15) skeins. Yarn distributed by Tahki/Stacy Charles.
needles • Size 8 (5 mm): 16" and 24" (40 and 60 cm) circular (cir). Adjust needle size if necessary to obtain the correct gauge. **notions** • Markers (m); waste yarn; tapestry needle.

gauge it

18 sts and 23 rnds = 4" (10 cm) in St st, worked in the rnd.

note it

oblique rib: (multiple of 4 sts)

rnd 1: *K2 through back loop (tbl), p2; rep from * around.

rnd 2: P1, *k2 tbl, p2; rep from * to last 3 sts, k2 tbl, p1.

rnd 3: *P2, k2 tbl; rep from * around.

rnd 4: K1 tbl, *p2, k2 tbl; rep from * to last 3 sts, p2, k1 tbl. Repeat Rnds 1–4 for pattern.

knit it

body • **neck:** With longer cir needle, CO 76 sts. Do not join into a rnd. Work back and forth in rows as foll:

row 1: (WS) P3 for right front, place marker (pm), p16 for right sleeve, pm, p38 for back, pm, p16 for left sleeve, pm, p3 for left front.

row 2: [Knit into the front and back of next st (k1f&b)] 2 times, k1, slip marker (sl m), k1f&b, *knit to 2 sts before next marker, k1f&b, k1, sl m, k1f&b; rep from * to last 2 sts, k1f&b, k1—86 sts.

row 3 and all WS rows: Purl.

rows 4, 6, and 8: K1f&b, *knit to 2 sts before next marker, k1f&b, k1, sl m, k1f&b; rep from * to last 2 sts, k1f&b, k1—10 sts inc'd each row; 116 sts after Row 8.

Do not turn work at the end of Row 8. With RS still facing, use the backward loop method (see Know It, page 54) to CO 24 sts onto right needle tip—140 sts total. Pm (use a different color marker here to denote beg of rnd) and join for working in the rnd, being careful not to twist sts. Knit 1 rnd.

shape raglan: Working in rnds, inc at each marker as foll:

rnd 1: *Knit to 2 sts before marker, k1f&b, k1, sl m, k1f&b; rep from * 3 more times, knit to end of rnd—8 sts inc'd.

rnd 2: Knit even.

Rep these 2 rnds 20 (22, 24, 26) more times—308 (324, 340, 356) sts total; 88 (92, 96, 100) sts each for front and back, 66 (70, 74, 78) sts for each sleeve.

divide for body and sleeves: Removing all raglan markers as you work, cont as foll: Knit to first marker, place next 66 (70, 74, 78) sts on waste yarn for one sleeve, use the backward loop method to CO 5 sts onto the right needle tip, placing a marker between the first and second CO st to mark the side "seam," knit to next marker, place next 66 (70, 74, 78) sts on waste yarn for other sleeve, use the backward loop method to CO 5 sts onto the right needle tip, again placing a marker between the first and second CO st to mark the other side "seam," knit to end of rnd—186 (194, 202, 210) body sts rem; 93 (97, 101, 105) sts each for front and back.

lower body: Knit to side seam marker, p1, k1, p1, knit to next side seam marker, p1, k1, p1, knit to end of rnd. Rep the last rnd until side seam measures 15 (15½, 16, 16½)" (38 [39.5, 40.5, 42] cm) from dividing rnd. **Next rnd:** Knit, dec 2 sts evenly spaced and remove side seam markers—184 (192, 200, 208) sts rem. Work Rnds 1 and 2 of oblique rib patt (see Note It). Knit 3 rnds even. BO all sts knitwise.

sleeves • Place 66 (70, 74, 78) held sleeve sts onto shorter cir needle. Join yarn with RS facing, and pick up and knit 4 sts along underarm BO, placing a marker for beg of rnd between the 2nd and 3rd picked-up sts, knit to end of rnd—70 (74, 78, 82) sts. Knit 5 rnds.

shape sleeve: *Dec rnd:* K1, ssk (see Know It, page 55), knit to last 3 sts, k2tog, k1—2 sts dec'd. Work 6 (5, 5, 4) rnds even. Rep the last 7 (6, 6, 5) rnds 10 (12, 4, 16) more times—48 (48, 68, 48) sts rem. *For size 45" (114.5 cm) only:* Rep dec rnd every 5th rnd 10 more times—48 sts rem (all sizes); sleeve measures 14½ (14½, 15, 15¾)" (37 [37, 38, 40] cm) from armhole.

cuff: Knit 1 rnd even. Work Rnds 1–4 of oblique rib patt 5 times. Knit 3 rnds even. Loosely BO all sts knitwise.

finish it

neckband: With shorter cir needle and beg at one shoulder, pick up and knit 108 sts around neck opening. Work Rnds 1–4 of oblique rib patt 2 times. Knit 3 rnds. BO all sts knitwise.

Weave in loose ends. Block to measurements. □

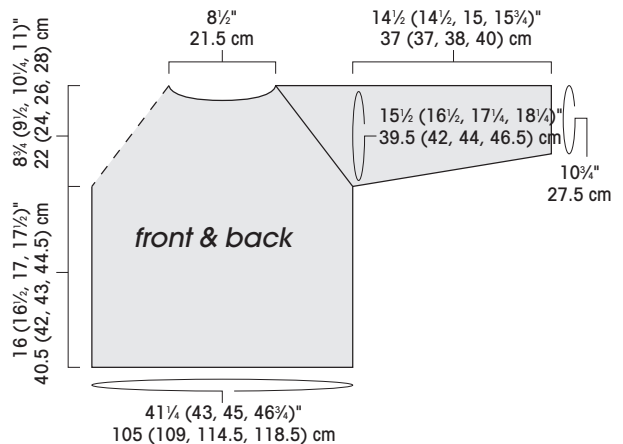

striped scarf page 43

Doris Chan

●○○○ I've learned the basic stitches

size it

About 8" (20.5 cm) wide and 72" (183 cm) long, excluding fringe.

gather it

yarn • Filatura di Crosa Zara (100% extra-fine merino wool; 137 yd [125 m]/50 g): #1888 dark green (A), 2 balls; #1404 black (B), #1481 blue (C), #1731 rust (D), #1490 dark blue (E), and #1718 gold (F), 1 ball each. **hook** • Size H/8 (5 mm). Adjust hook size if necessary to obtain the correct gauge. **notions** • Tapestry needle.



gauge it

12 hdc and 12 rows hdc = 4" (10 cm).

note it

The 8" (20.5-cm) tails at the beg and end of the stripes will be tucked into the fringe later, eliminating the need to weave in ends.

To eliminate the "gap" that typically forms at the beg of hdc rows, the ch-2 turning ch (tch) at beg of each row is not counted as a stitch; do not work that tch at the end of the row; just ignore it.

crochet it

With A and leaving an 8" (20.5-cm) tail, make a chain 218 sts long. Hdc in 3rd ch from hook and in each ch to end—216 hdc. Fasten off A, leaving an 8" (20.5-cm) tail. Turn.

row 1: Leaving an 8" (20.5-cm) tail, join A in first hdc, ch 2, hdc in same hdc, hdc in each hdc to end, leaving tch unworked—216 hdc. Fasten off, leaving an 8" (20.5-cm) tail. Turn.

Rep Row 1 in the foll color sequence: 2 rows B, 2 rows C, 2 rows D, 2 rows E, 1 row F, 2 rows A, 2 rows C, 2 rows B, 2 rows D, 2 rows A, 1 row F, 2 rows E—24 rows total.

finish it

fringe: Knot yarn tails together along each edge, matching colors. Cut 144 lengths of yarn, each 18" (45.5 cm) long, in the foll colors: 36 in A; 24 each in B, C, D, and E; 12 in F. Holding 3 strands of same color tog, fold strands in half. Use crochet hook to pull loop through same color row-end hdc, pull ends of yarn and tail from row through loop and tighten. Rep for each row-end hdc, using corresponding color strands. Trim ends to 8" (20.5 cm).

Weave in loose ends. Block lightly, if desired. □

crochet slippers page 43

doris chan

●●●● I'm ready for a challenge

on the web knitscene.com

Instructions for children's sizes (shown on page 32).

size it

8½ (9, 9½, 10, 10½, 11)" (21.5 [23, 24, 25.5, 26.5, 28] cm) from back of heel to tip of toe. To fit women's U.S. shoe sizes 4½ (6, 7½, 9, 10½, 12) and men's U. S. shoe sizes 3½ (5½, 6½, 8, 9½, 11). Slippers shown measure 9" (23 cm) and 10½" (26.5 cm).



gather it

yarn • Filatura di Crosa Zara Plus (100% merino wool; 76 yd [70 m]/50 g): Women's sizes (shown on page 28) 8½–9½" (21.5–24 cm): #25 dark red (C), #22 rose (A), and #403 pink (B), 2 balls each. Men's sizes 10–11" (25.5–28 cm): #19 dark green (A), #405 rust (C), and #30 black (B), 2 balls each. Yarn distributed by Tahki/Stacy Charles. **hook** • Size I/9 (5.5 mm). Adjust hook size if necessary to obtain the correct gauge. **notions** • Waste yarn or markers (m); tapestry needle.

gauge it

15 sts = 4" (10 cm) in sc or cluster patt; 9 rows sc or 2 rows clusters = 2" (5 cm).

note it

cluster (cl): Yo, insert hook into st and draw up a loop, yo and draw through 2 loops, [yo, insert hook into same st and draw up a loop, yo and draw through 2 loops] 2 times, yo and draw through all 4 loops on hook.

beginning cluster (beg cl): Ch 2, [yo, insert hook into st and draw up a loop, yo and draw through 2 loops] 2 times, yo and draw through all 3 loops on hook.

cl2tog (dec): Cl in next ch-sp, holding back last 4 loops on hook, cl in next ch-sp, holding back last 3 loops, yo and draw through all 7 loops on hook.

The soles are worked in the round, with the join placed at center of heel. The foot is also worked in the round, with RS always facing.

When working single crochet in joined rnds back and forth, skip the first stitch after turning, then work the next actual single crochet for the first stitch of the row. At the end of the row, work the single crochet with the attached slipped stitch as last single crochet of the row.

crochet it

sole • (make two)

rnd 1: (RS) With A, ch 21 (23, 25, 25, 27, 29), 2 sc in 2nd ch from hook, sc in next 18 (20, 22, 22, 24, 26) ch, 3 sc in last ch for toe, sc in next 18 (20, 22, 22, 24, 26) spare loops of ch, 2 sc in same ch as beg, sl st in beg sc, turn—43 (47, 51, 51, 55, 59) sc.

rnd 2: Ch 1, skip sl st, sc in next sc, 2 sc in next sc, sc in next 9 (10, 11, 11, 12, 13) sc, hdc in next sc, dc in next 9 (10, 11, 11, 12, 13) sc, 7 dc in next sc for toe, dc in next 9 (10, 11, 11, 12, 13) sc, hdc in next sc, sc in next 9 (10, 11, 11, 12, 13) sc, 2 sc in next sc, sc in last sc, sl st in beg sc, turn—51 (55, 59, 59, 63, 67) sts.

rnd 3: Ch 1, skip sl st, sc in next sc, 2 sc in next sc, sc in next 12 (13, 14, 14, 15, 16) sts, hdc in next st, dc in next 8 (9, 10, 10, 11, 12) sts, 2 sc in next 5 sts, dc in next 8 (9, 10, 10, 11, 12) sts, hdc in next st, sc in next 12 (13, 14, 14, 15, 16) sts, 2 sc in next sc, sc in last sc, sl st in beg sc, turn—58 (62, 66, 66, 70, 74) sts.

rnd 4: Ch 1, skip sl st, sc in next sc, 2 sc in next 2 sts, sc in next 21 (23, 25, 25, 27, 29) sts, [2 sc in next st, sc in next 2 st] 3 times, 2 sc in next st, sc in next 21 (23, 25, 25, 27, 29) sts, 2 sc in next 2 sts, sc in last st, sl st in beg sc, turn—66 (70, 74, 74, 78, 82) sc.

Sizes 8½ (9, 9½)" only: Ch 1, skip sl st, sc in next sc, 2 sc in next sc, sc in next 62 (66, 70) sc, 2 sc in next sc, sc in last sc, sl st in beg sc—68 (72, 76) sc. Fasten off A.

Sizes 10 (10½, 11)" only: Ch 1, skip sl st, sc in next sc, 2 sc in next sc, sc in next 30 (32, 34) sc, [2 sc in next sc, sc in next 2 sc] 3 times, 2 sc in next sc, sc in next 30 (32, 34) sc, 2 sc in next sc, sc in last sc, sl st in beg sc, turn—80 (84, 88) sc.

All sizes: Ch 1, skip sl st, sc in each sc around, sl st in beg sc—68 (72, 76, 80, 84, 88) sc. Fasten off A.

foot • With RS of sole facing, work in rnds as foll:

rnd 1: With B, skip sl st, join with sl st in next sc, beg cl in same sc, [ch 1, skip next sc, cl in next sc] 33 (35, 37, 39, 41, 43) times, ch 1, skip last sc, sl st in beg cl—34 (36, 38, 40, 42, 44) clusters. Fasten off B.

rnd 2: With C, join with sl st in last ch-sp made, beg cl in same sp, [ch 1, cl in next ch-sp] 33 (35, 37, 39, 41, 43) times, ch 1, sl st in top of beg cl—34 (36, 38, 40, 42, 44) clusters. Fasten off C.

rnd 3: With A, join with sl st in last ch-sp made, beg cl in same sp, holding back last 3 loops, cl in next ch-sp, holding back last 3 loops, yo and draw through all 6 loops on hook for beg dec, [ch 1, cl in next ch-sp] 13 (14, 15, 16, 17, 18) times, [ch 1, cl2tog] 3 times, [ch 1, cl in next ch-sp] 13 (14, 15, 16, 17, 18) times, ch 1, sl st in top of beg cl—30 (32, 34, 36, 38, 40) clusters. Fasten off A.

vamp (instep) • (make 2)

Sizes 8½ (9, 9½)" only:

rnd 1: With C, ch 14, 2 sc in 2nd ch from hook, sc in next 11 ch, 4 sc in last ch, sc in 11 spare loops of ch, 2 sc in same ch as beg, sl st in beg ch, turn—30 sc.

rnd 2: Ch 1, [sc in next sc, 2 sc in next sc, sc in next 11 sc, 2 sc in next sc, sc in next sc] 2 times, sl st in beg sc, turn—34 sc.

rnd 3: Ch 1, [sc in next sc, 2 sc in next 2 sc, sc in next 11 sc, 2 sc in next 2 sc, sc in next sc] 2 times, sl st in beg sc, turn—42 sc.

rnd 4: Ch 1, [sc in next sc, 2 sc in next sc, sc in next 17 sc, 2 sc in next sc, sc in next sc] 2 times, sl st in beg sc, turn—46 sc.

rnd 5: Ch 1, [sc in next sc, 2 sc in next sc, sc in next 19 sc,

2 sc in next sc, sc in next sc] 2 times, sl st in beg sc—50 sc. Fasten off.

Weave in loose ends. From the join, skip next 17 sc, mark 18th sc; rep for other side of join—36 sc around toe for assembly. *Sizes 10 (10½, 11)" only:*

rnd 1: With C, ch 14, 2 sc in 2nd ch from hook, sc in next 11 ch, 4 sc in last ch, sc in 11 spare loops of ch, 2 sc in same ch as beg, sl st in beg ch, turn—30 sc.

rnd 2: Ch 1, [sc in next sc, 2 sc in next sc, sc in next 11 sc, 2 sc in next sc, sc in next sc] 2 times, sl st in beg sc, turn—34 sc.

rnd 3: Ch 1, [sc in next sc, 2 sc in next 2 sc, sc in next 11 sc, 2 sc in next 2 sc, sc in next sc] 2 times, sl st in beg sc, turn—42 sc.

rnd 4: Ch 1, [2 sc in next 2 sc, sc in next 17 sc, 2 sc in next 2 sc] 2 times, sl st in beg sc, turn—50 sc.

rnd 5: Ch 1, [2 sc in next sc, sc in next 23 sc, 2 sc in next sc] 2 times, sl st in beg sc—54 sc. Fasten off.

Weave in loose ends. From the join, skip next 19 sc, mark 20th sc; rep for other side of join—40 sc around toe for assembly.

finish it

Counting each cluster and ch-sp as a st, there are 60 (64, 68, 72, 76, 80) sts around top of foot. (*Note:* For a snug fit around the ankle, make the sc of the next round firmly.) With B and RS of foot facing, join with sl st in last cluster made, ch 1, sc in same st, sc in next 12 (14, 16, 16, 18, 20) sts. Match next st of foot with marked sc of vamp, matching 36 (36, 36, 40, 40, 40) sts around toe. Sc tog through both thicknesses for 36 (36, 36, 40, 40, 40) sc around toe. Sc in next 11 (13, 15, 15, 17, 19) sts of foot to end, sl st in beg sc—60 (64, 68, 72, 76, 80) sc. Fasten off. Weave in loose ends. ☐



●●●○ I'm feeling pretty confident

size it

38 (42, 46, 50)" (96.5 [106.5, 117, 127] cm) bust circumference. Sweater shown measures 42" (106.5 cm).



gather it

yarn • Tahki Baby Tweed (92% wool, 8% viscose; 60 yd [55 m]/100 g): #7 red, 12 (13, 15, 16) balls. **needles** • Size 17 (12 mm): 29" (70 cm) or longer circular (cir). Adjust needle size if necessary to obtain the correct gauge. **notions** • Cable needle (cn); markers (m); removable markers or safety pins; stitch holders; tapestry needle.

gauge it

8 sts and 12 rows = 4" (10 cm) in St st.

note it

left cross: Sl 1 st onto cn and hold in front, p1, k1 from cn.

right cross: Sl 1 st onto cn and hold in back, k1, p1 from cn.

pattern 1: (multiple of 6 sts)

rows 1 and 3: (RS) *K3, p1, k1, p1; rep from *.

row 2: *K3, p3; rep from *.

row 4: Purl.

rows 5 and 7: *P1, k1, p1, k3; rep from *.

row 6: *P3, k3; rep from *.

row 8: Purl.

Repeat Rows 1–8 for pattern.

pattern 2: (multiple of 6 sts)

row 1: (RS) *P2, k1; rep from *.

row 2: Purl.

rows 3–10: Rep Rows 1 and 2 four more times.

row 11: *P2, k4; rep from *.

row 12: Purl.

Repeat Rows 1–12 for pattern.

pattern 3: (multiple of 6 sts)

rows 1 and 3: (RS) *K3, p2, k1; rep from *.

rows 2, 4, and 6: Purl.

rows 5 and 7: *P2, k4; rep from *.

row 8: Purl.

Repeat Rows 1–8 for pattern.

pattern 4: (multiple of 6 sts)

rows 1, 3, and 5: (RS) *K2, p2, k2; rep from *.

rows 2, 4, and 6: Purl.

row 7: *K1, right cross, left cross, k1; rep from *.

rows 8, 10, and 12: Purl.

rows 9 and 11: *K1, p1, k2, p1, k1; rep from *.

row 13: *K1, right cross, left cross, k1; rep from *.

row 14: Purl.

Repeat Rows 3–14 only for pattern on subsequent repeats; work Rows 1 and 2 at beginning of first repeat only.

pattern 5: (multiple of 6 sts + 3)

rows 1 and 3: (RS) *K3, p1, k1, p1; rep from * to last 3 sts, k3.

row 2: *P3, k3; rep from * to last 3 sts, p3.

row 4: Purl.

rows 5 and 7: *P1, k1, p1, k3; rep from * to last 3 sts, p1, k1, p1.

row 6: *K3, p3; rep from * to last 3 sts, k3.

row 8: Purl.

Repeat Rows 1–8 for pattern.

pattern 6: (multiple of 6 sts + 3)

row 1: (RS) *P2, k1; rep from *.

row 2: Purl.

rows 3–10: Rep Rows 1 and 2 four more times.

row 11: *P2, k4; rep from * to last 3 sts, p2, k1.

row 12: Purl.

Repeat Rows 1–12 for pattern.

pattern 7: (multiple of 6 sts + 3)

rows 1 and 3: (RS) *K3, p2, k1; rep from * to last 3 sts, k3.

rows 2, 4, and 6: Purl.

rows 5 and 7: *P2, k4; rep from * to last 3 sts, p2, k1.

row 8: Purl.

Repeat Rows 1–8 for pattern.

right front edge: (worked over 4 sts)

set-up row: (RS) K2, p1, k1.

all WS rows: P1, k1, p2.

all RS rows: Sl 1 as if to knit, k1, p1, k1.

Repeat RS and WS rows for pattern; do not repeat set-up row.

left front edge: (worked over 4 sts)

set-up row: (RS) K1, p1, k2.

all WS rows: Sl 1 as if to purl, p1, k1, p1.

all RS rows: K1, p1, k2.

Repeat RS and WS rows for pattern; do not repeat set-up row.

The side seams use up one stitch at each side for the garment body and sleeves. The measurements on the schematic show the actual size of the pieces, including all stitches, for blocking purposes. However, the stitches lost in the seams are not counted toward the finished bust size.

If there are not enough stitches to work a right or left cross in Pattern 4 as a result of shaping, work the stitch that has no crossing companion in stockinette stitch instead.

knit it

back • CO 40 (44, 48, 52) sts. *K1, p1; rep from *. Work 6 rows total in rib, ending with a WS row—piece measures about 2¼" (5.5 cm) from CO.

pattern 1: (RS) Work 2 (1, 3, 2) st(s) in St st, work center 36 (42, 42, 48) sts according to Row 1 of Pattern 1 (see Note It), work 2 (1, 3, 2) st(s) in St st. Cont in patt until Rows 1–8 of Pattern 1 have been worked a total of 2 times—16 rows total in Pattern 1; piece measures about 7½" (19 cm) from

CO. Knit 1 row, purl 1 row.

pattern 2: (RS) Work 2 (1, 3, 2) st(s) in St st, work center 36 (42, 42, 48) sts according to Row 1 of Pattern 2, work 2 (1, 3, 2) st(s) in St st. Cont in patt until Row 12 of Pattern 2 has been completed.

pattern 3: (RS) Work 2 (1, 3, 2) st(s) in St st, work center 36 (42, 42, 48) sts according to Row 1 of Pattern 3, work 2 (1, 3, 2) st(s) in St st. Cont in patt until Row 8 of Pattern 3 has been completed, then work Rows 1–4 once more—12 rows total in Pattern 3; piece measures about 16¼" (41.5 cm) from CO. Work 8 rows even in St st, ending with a WS row—piece measures about 19" (48.5 cm) from CO.

pattern 4: (RS) Work 2 (1, 3, 2) st(s) in St st, work center 36 (42, 42, 48) sts according to Row 1 of Pattern 4, work 2 (1, 3, 2) st(s) in St st. Cont in patt until Row 8 of Pattern 4 has been completed; piece measures about 21½" (54.5 cm) from CO.

shape armholes: Cont in Pattern 4, and at the same time, beg with Row 9 of patt, BO 3 sts at beg of next 2 rows—34 (38, 42, 46) sts rem. On the next RS row, dec 1 st at each end of needle—32 (36, 40, 44) sts rem. Cont even in patt until armholes measure 7½ (8, 8½, 8½)" (19 [20.5, 21.5, 21.5] cm), ending with a WS row.

shape neck and shoulders: With removable markers or safety pins, mark center 12 (12, 14, 16) sts for back neck. *Next row:* (RS) BO 5 (6, 6, 7) sts, worked to marked center sts, join a second ball of yarn and BO center 12 (12, 14, 16) sts, work to end. On the next WS row, BO 5 (6, 6, 7) sts at beg of first group of sts, work even across second group of sts—5 (6, 7, 7) sts rem at each side. On the next RS row, BO first group of 5 (6, 7, 7) sts, work even across second group of sts. BO rem 5 (6, 7, 7) sts on foll WS row.

right front • CO 21 (23, 25, 28) sts. With RS facing, work 4 sts for right front edge (see Note It), *p1, k1; rep from * to last st, p1. Work 5 more rows, working edge sts in patt, and working rib sts as they appear, ending with a WS row—6 rows completed; piece measures about 2¼" (5.5 cm) from CO.

pattern 1: (RS) Work 4 right front edge sts, work 12 (18, 18, 24) sts according to Row 1 of Pattern 1, work 5 (1, 3, 0) st(s)

in St st. Cont in patt until Rows 1–8 of Pattern 1 have been worked a total of 2 times—16 rows total in Pattern 1; piece measures about 7½" (19 cm) from CO. Keeping 4 right front edge sts in patt and rem sts in St st, work 2 rows even.

pattern 2: (RS) Work 4 right front edge sts, work 12 (18, 18, 24) sts according to Row 1 of Pattern 2, work 5 (1, 3, 0) st(s) in St st. Cont in patt until Row 12 of Pattern 2 has been completed.

pattern 3: (RS) Work 4 right front edge sts, work 12 (18, 18, 24) sts according to Row 1 of Pattern 3, work 5 (1, 3, 0) st(s) in St st. Cont in patt until Row 8 of Pattern 3 has been completed, then work Rows 1–4 once more—12 rows total in Pattern 3; piece measures about 16¼" (41.5 cm) from CO. Work 8 rows even in St st, or same number of rows worked even as for back if you adjusted the length, ending with a WS row—piece measures about 19" (48.5 cm) from CO.

pattern 4: (RS) Work 4 right front edge sts, work 12 (18, 18, 24) sts according to Row 1 of Pattern 4, work 5 (1, 3, 0) st(s) in St st. Cont in patt until Row 9 of Pattern 4 has been completed; piece measures about 21½" (54.5 cm) from CO.

shape armhole: Cont in Pattern 4, and *at the same time*, beg with Row 10 of patt, BO 3 sts at beg of next WS row—18 (20, 22, 25) sts rem. Work 1 row even. Dec 1 st at beg of foll WS row—17 (19, 21, 24) sts rem. Cont even in patt until armhole measures 4 (4½, 5, 5)" (10 [11.5, 12.5, 12.5] cm), ending with a WS row.

shape neck: (RS) Work 4 edge sts and place these sts on a holder, work in patt to end—13 (15, 17, 20) sts rem. Work 1 WS row even in patt. Cont in patt, dec 1 st at neck edge (beg of RS rows, end of WS rows) every row 0 (0, 0, 4) times, then every other row 3 (3, 4, 2) times—10 (12, 13, 14) sts rem. Work even, if necessary for your size, until armhole measures 7½ (8, 8½, 8½)" (19 [20.5, 21.5, 21.5] cm), ending with a RS row.

shape shoulder: BO 5 (6, 6, 7) sts at beg of next WS row, then BO 5 (6, 7, 7) sts at beg of foll WS row.

left front • CO 21 (23, 25, 28) sts. With RS facing, *k1, p1; rep from * to last st 5 sts, k1, work 4 sts for left front edge (see Note It). Work 5 more rows, working edge sts in patt, and

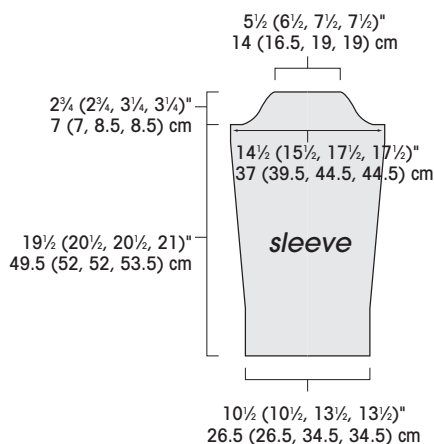
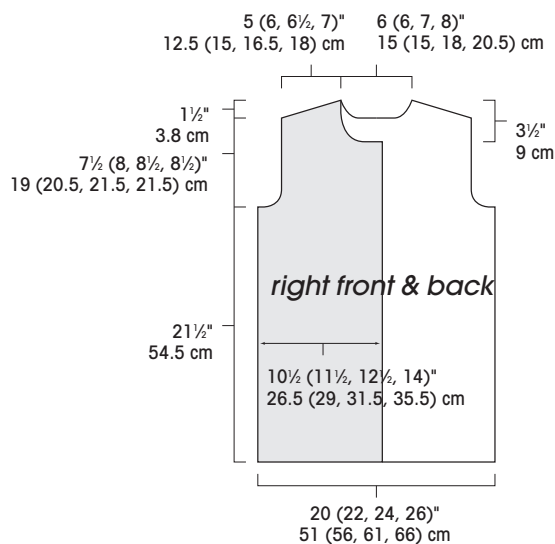

working rib sts as they appear, ending with a WS row—6 rows completed; piece measures about 2¼" (5.5 cm) from CO.

pattern 1: (RS) Work 5 (1, 3, 0) st(s) in St st, work 12 (18, 18, 24) sts according to Row 1 of Pattern 1, work 4 left front edge sts. Cont in patt until Rows 1–8 of Pattern 1 have been worked a total of 2 times—16 rows total in Pattern 1; piece measures about 7½" (19 cm) from CO. Keeping 4 left front edge sts in patt and working rem sts in St st, work 2 rows even.

pattern 2: (RS) Work 5 (1, 3, 0) st(s) in St st, work 12 (18, 18, 24) sts according to Row 1 of Pattern 2, work 4 left front edge sts. Cont in patt until Row 12 of Pattern 2 has been completed.

pattern 3: (RS) Work 5 (1, 3, 0) st(s) in St st, work 12 (18, 18, 24) sts according to Row 1 of Pattern 3, work 4 left front edge sts. Cont in patt until Row 8 of Pattern 3 has been completed, then work Rows 1–4 once more—12 rows total in Pattern 3; piece measures about 16¼" (41.5 cm) from CO. Work 8 rows even in St st, ending with a RS row—piece measures about 19" (48.5 cm) from CO.

pattern 4: (RS) Work 5 (1, 3, 0) st(s) in St st, work 12 (18, 18, 24) sts according to Row 1 of Pattern 4, work 4 left front edge sts. Cont in patt until Row 8 of Pattern 4 has been completed; piece measures about 21½" (54.5 cm) from CO.

shape armhole: Cont in Pattern 4, and *at the same time*, beg with Row 9 of patt, BO 3 sts at beg of next RS row—18 (20, 22, 25) sts rem. Work 1 row even. Dec 1 st at beg of next RS row—17 (19, 21, 24) sts rem. Cont even in patt until armhole measures 4 (4½, 5, 5)" (10 [11.5, 12.5, 12.5] cm), ending with a RS row.

shape neck: (WS) Work 4 edge sts, place sts just worked on holder, work in patt to end—13 (15, 17, 20) sts rem. Work 1 RS row even in patt. Cont in patt, dec 1 st at neck edge (beg of WS rows; end of RS rows) every row 0 (0, 0, 4) times, then every other row 3 (3, 4, 2) times—10 (12, 13, 14) sts rem. Work even, if necessary for your size, until armhole measures 7½ (8, 8½, 8½)" (19 [20.5, 21.5, 21.5] cm), ending with a WS row.

shape shoulder: BO 5 (6, 6, 7) sts at beg of next RS row, then BO 5 (6, 7, 7) sts at beg of foll RS row.

sleeves • (make 2) CO 20 (22, 24, 26) sts. With RS facing, *k2, p2; rep from * to last 0 (2, 0, 2) sts, end k0 (2, 0, 2). Work 9 rows total in rib, ending with a RS row. On the next WS row, work in rib, inc 1 (dec 1, inc 3, inc 1) st—21 (21, 27, 27) sts; piece measures about 3¾" (9.5 cm) from CO.

pattern 5: Work Rows 1 and 2 of Pattern 5 across all sts. On the next RS row (Row 3 of patt), work 1 st in patt, pm, M1 (see Know It, page 55), work in patt to last st, M1, pm, work 1 st in patt—23 (23, 29, 29) sts; 21 (21, 27, 27) sts between markers for patt. Slip markers (sl m) every row. Working new sts outside markers in St st, work until Row 8 of patt has been completed, then work Rows 1–4 once more. *Inc row:* (RS) K1, M1, knit to marker, sl m, work in patt across center 21 (21, 27, 27) sts, sl m, knit to last st, M1, k1—2 sts inc'd. Work 3 more rows in patt, ending with Row 8 of Pattern 5—25 (25, 31, 31) sts; piece measures about 9" (23 cm) from CO. Work 2 rows even in St st, ending with a WS row.

pattern 6: (RS) Work in St st to marker, work center 21 (21, 27, 27) sts according to Row 1 of Pattern 6, work in St st to end. Working inc row on Row 5, cont in patt until Row 12 of Pattern 6 has been completed—27 (27, 33, 33) sts; piece meas-

ures about 13¾" (35 cm) from CO.

pattern 7: (RS) Inc 1 st at each end of row as for inc row, and work Row 1 of Pattern 7 over center 21 (21, 27, 27) sts—29 (29, 35, 35) sts. *Note:* Pattern 7 continues through rem sleeve shaping and start of sleeve cap shaping; read the next sections all the way through before proceeding. Work in Pattern 7 until 16 (16, 16, 20) rows of patt have been completed, then cont to end of sleeve cap in St st. *At the same time*, work inc row every 0 (6, 0, 0) rows 0 (1, 0, 0) more time(s)—29 (31, 35, 35) sts. Work even in patt until piece measures 19½ (20½, 20½, 21)" (49.5 [52, 52, 53.5] cm) from CO, ending with a WS row.

shape cap: Cont in patt, BO 3 sts at beg of next 2 rows—23 (25, 29, 29) sts rem. BO 0 (1, 1, 1) st at beg of next 0 (2, 4, 4) rows, then BO 2 sts at beg of next 6 (2, 2, 2) rows, then BO 0 (3, 3, 3) sts at beg of foll 0 (2, 2, 2) rows—11 (13, 15, 15) sts rem. BO all sts.

finish it

Block pieces gently to measurements. With yarn threaded on a tapestry needle, sew shoulder seams.

collar: Return 4 held left front sts to needle with WS facing and join yarn at left front edge. P2, k1, p1 (left front edge sts), place marker (pm), pick up and knit 27 (27, 30, 33) sts evenly around neck opening to 4 held right front sts, pm, return held right front sts to needle, p1, k1, p2 (right front edge sts)—35 (35, 38, 41) sts total.

row 1: (RS) K2, *p1, k2; rep from * to end.

row 2: *P2, k1; rep from * to last 2 sts, p2.

Rep these 2 rows until collar measures 5¼" (13.5 cm) from pick-up. BO all sts in patt.

Sew sleeves into armholes. Sew side and sleeve seams.

Weave in loose ends. ☐

lucky star belt page 44 Mary Jane Mucklestone

●○○○ I've learned the basic stitches

size it

1¾" (4.5 cm) wide and 77½" (197 cm) long, excluding fringe.

gather it

yarn • Tahki Select Star (60% tadel nylon, 40% metallic polyester; 163 yd [149 m]/20 g): #003 silver multi, 4 balls (4 strands used together). Tahki Select Lucky (100% nylon; 54 yd [49 m]/50 g): #012 wine, 1 ball. hook • Size I/9 (5.5 mm). Adjust hook size if necessary to obtain the correct gauge. notions • Tapestry needle.

gauge it

14 sc = 4" (10 cm) with 4 strands of yarn held together.

crochet it

foundation chain: With 4 strands of Star held tog, ch 272.

row 1: Sc in 2nd ch from hook and in each ch across—271 sc. Turn.



rows 2 and 4: Ch 3 (counts as 1 dc), *dc in each of next 2 sc, ch 1, skip 1 sc; rep from * until 3 sc rem, dc in each of last 3 dc. Turn.

rows 3 and 5: Ch 1, sc in each dc and each ch-sp across. Turn.
Fasten off.

finish it

Weave in loose ends.

fringe: (make 8) For each fringe, cut 72" (183 cm) of Star and fold in half. Use crochet hook to pull fold through short end of belt. Keeping fold on hook to use as starting loop, work a chain about 9" (23 cm) long. Fasten off. Tie end of chain in an overhand knot and trim tails. Attach 4 fringes to each short end of belt.

trim: Cut two 92" (233.5-cm) lengths of Lucky. With tapestry needle, thread through channels on Rows 2 and 4 of belt, leaving about 7" (18 cm) of tail at each end. □

striped pullover page 45 norah gaughan

●●●○ I'm feeling pretty confident

size it

40½ (44, 47½, 51)" (103 [112, 120.5, 129.5] cm) chest circumference. Sweater shown measures 47½" (120.5 cm).



gather it

yarn • Classic Elite Skye Tweed (100% wool; 112 yd [102 m]/50 g): #1215 spruce green (dark green), 6 (6, 6, 7) balls; #1238 highland cow brown (deep rust), 5 (5, 5, 6) balls; #1272 upland green (pale green) and #1285 MacAlister orange, 2 (2, 2, 3) balls each; #1258 tartan red (red), 1 (1, 1, 2) ball(s). needles • Sizes 5 (3.75 mm) and 7 (4.5 mm). Adjust needle size if necessary to obtain the correct gauge.
notions • Removable markers or safety pins; tapestry needle.

gauge it

18½ sts and 31 rows = 4" (10 cm) in slip-st stripe pattern with larger needles.

note it

slip-stitch stripe pattern: (multiple of 4 sts + 2)

row 1: (RS) *P2 red, sl 2 sts with yarn in front (wyf); rep from * to last 2 sts, p2 red.

row 2: (WS) Purl with red.

row 3: *P2 pale green, sl 2 sts wyf; rep from * to last 2 sts, p2 pale green.

rows 4 and 6: Purl with pale green.

row 5: Knit with pale green.

row 7: *P2 deep rust, sl 2 sts wyf; rep from * to last 2 sts, p2 deep rust.

rows 8, 10, 12, and 14: Purl with deep rust.

rows 9, 11, and 13: Knit with deep rust.

row 15: *P2 orange, sl 2 sts wyf; rep from * to last 2 sts, p2 orange.

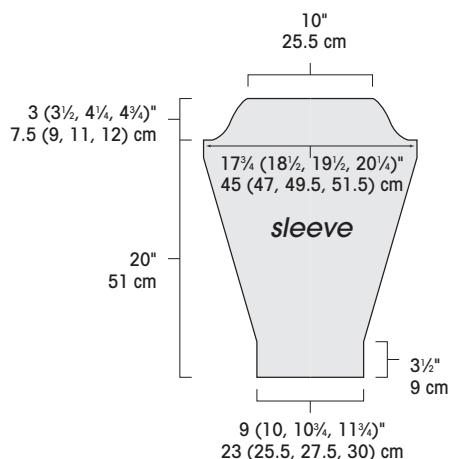
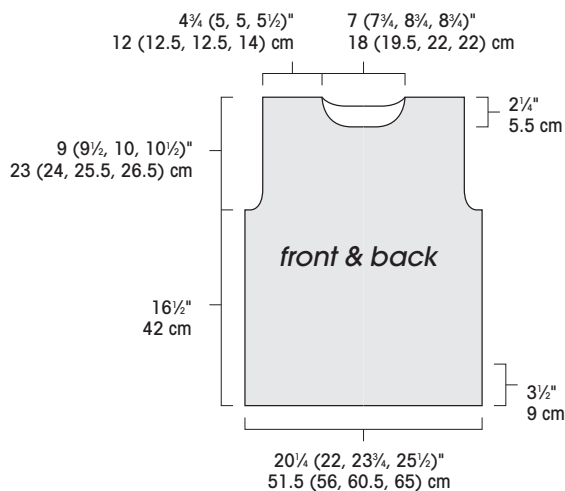

rows 16 and 18: Purl with orange.

row 17: Knit with orange.

row 19: *P2 dark green, sl 2 sts wyf; rep from * to last 2 sts, p2 dark green.

rows 20, 22, 24, and 26: Purl with dark green.

rows 21, 23, and 25: Knit with dark green.

Repeat Rows 1–26 for pattern.

knit it

back • With dark green and smaller needles, CO 94 (102, 110, 118) sts.

ribbing: *K2, p2; rep from * to last 2 sts, k2. Cont in rib as established (knit the knits; purl the purls) until piece measures 3½" (9 cm) from CO, ending with a WS row.

body: Change to larger needles and work even in slip-stitch stripe patt (see Note It) until piece measures 16½" (42 cm) from CO, ending with a WS row.

shape armholes: Keeping in patt and keeping slipped sts lined up with previous rows, BO 4 sts at beg of next 0 (0, 2, 2) rows, then BO 3 sts at beg of foll 2 (4, 2, 2) rows, then BO 2 sts at beg of foll 4 (2, 2, 4) rows—80 (86, 92, 96) sts rem. BO 1 st at beg of next 4 (4, 6, 4) rows—76 (82, 86, 92) sts rem. Work even until armholes measure 8½ (9, 9½, 10)" (21.5 [23, 24, 25.5] cm), ending with a WS row.

shape neck: Mark center 12 (16, 20, 20) sts. With RS facing, work in patt to marked sts, join a second ball of yarn and BO marked 12 (16, 20, 20) sts, work to end of row—32 (33, 33, 36) sts rem each side. Working each side separately, at each neck edge, BO 5 sts 2 times—22 (23, 23, 26) sts rem. BO all sts.

front • Work as for back until armholes measure $6\frac{3}{4}$ ($7\frac{1}{4}$, $7\frac{3}{4}$, $8\frac{1}{4}$)" (17 [18.5, 19.5, 21] cm), ending with a WS row—76 (82, 86, 92) sts rem.

shape neck: Mark center 12 (16, 20, 20) sts. With RS facing, work in patt to marked sts, join a second ball of yarn and BO marked 12 (16, 20, 20) sts, work to end of row—32 (33, 33, 36) sts rem each side. Working each side separately, at each neck edge, BO 4 sts once, then BO 3 sts once, then BO 2 sts once, then BO 1 st once—22 (23, 23, 26) sts rem each side. Work even until piece measures same as back to shoulder. BO all sts.

sleeves • (make 2) **cuff**: With dark green and smaller needles, CO 42 (46, 46, 50) sts. *K2, p2; rep from * to last 2 sts, k2. Cont in rib as established until piece measures $3\frac{1}{2}$ " (9 cm) from CO, ending with a RS row. *Next row*: (WS) Working in rib as established, inc 0 (0, 4, 4) sts evenly spaced—42 (46, 50, 54) sts.

arm: Change to larger needles and work slip-stitch stripe patt for 3 rows. *Next row*: (RS) K1, M1 (see Know It, page 55), knit to last st, M1, k1—2 sts inc'd. Work 5 rows even in patt. Cont in patt, rep the shaping of the last 6 rows 19 more times, working new sts into patt—82 (86, 90, 94) sts. Work even until piece measures 20" (51 cm) from beg, ending with a WS row. **shape cap**: BO 3 sts at beg of the next 2 rows, then BO 2 sts at beg of foll 2 rows—72 (76, 80, 84) sts rem. *Next row*: (RS) Ssk (see Know It, page 55), knit to last 2 sts, k2tog—2 sts dec'd. Dec 1 st each end of needle every RS row in this manner 7 (9, 11, 13) more times—56 sts rem for all sizes. BO 2 sts at beg of next 2 rows, then BO 3 sts at beg of foll 2 rows—46 sts rem. BO all sts.

finish it

With yarn threaded on a tapestry needle, sew one shoulder seam.

neckband: With deep rust, smaller needles, RS facing, and beg at open shoulder edge, pick up and knit 82 (90, 98, 98) sts evenly spaced around neck edge. *K2, p2; rep from * to last 2 sts, k2. Cont in rib as established until band measures $1\frac{1}{2}$ " (3.8 cm) from pick-up. BO all sts.

Sew rem shoulder and neckband seam. Sew sleeve caps into armholes. Sew sleeve and side seams. Weave in loose ends. Block lightly if desired. 

earflap hats page 45

●○○○ I've learned the basic stitches

size it

About 18–19 (20–22, 23)" (45.5–48.5 [51–56, 58.5] cm) head circumference. To fit a baby (child or woman, man). Shown in size 22" (56 cm) in Tahki Bunny Print (50% wool, 25%

alpaca, 25% acrylic; 81 yd [74 m]/50 g) in #023 pink multi; Black Forest Naturwolle (100% wool; 110 yd [100 m]/100 g) in #194 dune; and Classic Elite Beatrice (100% merino; 63 yd [57 m]/50 g) in #3253 sugar maple.



gather it

yarn • Any yarn of your choice, in any gauge. Amount can range anywhere from 90–130 yd (80–120 m) for a bulky yarn (12 sts = 4" [10 cm]) up to 240–360 yd (220–330 m) for a fingering-weight yarn (7 sts = 4" [10 cm]). **needles** • Any appropriate size for the yarn chosen: set of 4 or 5 double-pointed (dpn) and 16" (40 cm) circular (cir). **notions** • Markers (m); waste yarn; safety pins or removable markers; stitch holder; tapestry needle; pom-pom maker (optional).

gauge it

Any gauge that produces pleasing St st fabric with your chosen yarn and needles.

note it

See www.knitscene.com for specific instructions for these three hats.

To try hat on, thread waste yarn through stitches. Return stitches to the needle(s) to continue knitting.

knit it

crown • CO 6 sts. Divide sts onto 3 dpn so that there are 2 sts on each needle. Place marker (pm) and join for working in the rnd, being careful not to twist sts; rnd begins at the center back. Knit 1 rnd.

rnd 1: Inc 6 sts as foll: *K1, M1 (see Know It, page 55), pm; rep from * to end of rnd, omitting placing marker after the last rep; end-of-rnd marker is already in place—12 sts.

rnd 2: Knit.

rnd 3: Inc 6 sts as foll: *K2, M1, slip marker (sl m); rep from * to end of rnd—18 sts.

rnd 4: Knit.

Cont to inc 6 sts every other rnd in this manner, working 1 more st before the M1 in each subsequent inc rnd, until hat measures desired circumference—about 18–19 (20–22, 23)" (45.5–48.5 [51–56, 58.5] cm) to fit a baby (child or woman, man). You may add color or texture patterns in the next section, if desired. Change to cir needle, and cont working even in rnds (do not inc) until piece measures 8" (20.5 cm) from CO, or about 1" (2.5 cm) less than total desired depth.

brim • *Purl 1 rnd, knit 1 rnd; rep from * until brim measures 1" (2.5 cm), ending with a knit rnd, and placing a marker in the middle of the last rnd, directly opposite the end-of-rnd marker, to indicate center front.

mark placement of earflaps: Earflap width is a personal choice; it can range for 3" (7.5 cm) for a baby to 5" (12.5 cm) or more for an adult. Transfer sts to waste yarn. Try hat on with end-of-rnd marker at the back. Use safety pins or removable markers to indicate where you would like each earflap to begin and end. Take the hat off and fine-tune the positions of

the earflaps so that both earflaps have the same even number of sts, and so that the edges of the earflaps are the same distance from center front and back markers. Earflaps can be closer together at the back of the head to leave a wider opening between them for the face. *Next rnd:* BO purlwise to marked sts of first earflap, purl earflap sts, BO purlwise to marked sts of second earflap, purl earflap sts, BO purlwise to end of rnd—2 groups of earflap sts rem. Place sts for one earflap on a holder.

Earflaps • (make 2) With RS facing, join yarn to earflap sts, ready to work a RS row. Work garter st back and forth in rows (knit all sts every row) until piece measures 1" (2.5 cm). *Dec row:* (RS) K2, ssk (see Know It, page 55), work to last 4 sts, k2tog, k2—2 sts dec'd. Knit 1 (WS) row even. Rep the last 2 rows as necessary until 6 sts rem, ending with a WS row. *Next row:* (RS) K2, k2tog, k2—5 sts rem. With WS facing, BO all sts.

finish it

Weave in loose ends. Anything beyond that is up to you—add colorful braids, tassels, pom-poms, or embroidery to the earflaps and/or crown. For more variations, work the straight section of the hat in a fancy stitch or color pattern, or two! Use your imagination for infinite possibilities. ☐

comfy socks page 46

●●○○ I'm ready to move past scarves

size it

About 6¾ (8, 9¼)" (17 [20.5, 23.5] cm) circumference and 7 (9, 11)" (18 [23, 28] cm) long from back of heel to toe. To fit a child (woman, man).



gather it

yarn • Black Forest Naturwolle Tweed (100% wool; 110 yd [101 m]/100 g): #T2-33 red multi, 1 (2, 2) skeins. Yarn distributed by Muench Yarns. **needles** • Size 11 (8 mm): set of 4 double-pointed (dnp). Adjust needle size if necessary to obtain the correct gauge. **notions** • Stitch marker (m); tapestry needle.

gauge it

6 sts and 8 rnds = 2" (5 cm) in St st worked in the rnd.

knit it

leg • CO 20 (24, 28) sts. Divide sts as evenly as possible on 3 dnp, place marker (pm), and join for working in the rnd, being careful not to twist sts. Knit every rnd until piece measures about 5¾ (6½, 7¼)" (14.5 [16.5, 18.5] cm) from beg.

heel • heel flap: K5 (6, 7), turn work, p10 (12, 14). These 10 (12, 14) sts will be worked back and forth in rows for the heel flap; divide the rem 10 (12, 14) sts evenly on 2 dnp (5 [6, 7] sts each needle) and do not work them again until later. Work the 10 (12, 14) heel sts as foll:

row 1: (RS) *Sl 1 purlwise with yarn in back, k1; rep from *.
row 2: (WS) Sl 1 purlwise with yarn in front, purl to end.

Rep Rows 1 and 2 until a total of 10 (12, 14) rows have been worked, ending with a WS row.

turn heel: Work short-rows to shape heel as foll:

short-row 1: (RS) K5 (7, 9), ssk (see Know It, page 56), k1, turn.

short-row 2: (WS) Sl 1, p1 (3, 5), p2tog, p1, turn.

short-row 3: Sl 1, knit to 1 st before gap, ssk, k1, turn.

short-row 4: Sl 1, purl to 1 st before gap, p2tog, p1, turn—6 (8, 10) sts rem.

shape gusset: Cont in the rnd as foll:

rnd 1: With Needle 1, k6 (8, 10) heel sts, then pick up and knit 5 (6, 7) sts along edge of heel flap; with Needle 2, k10 (12, 14) instep sts; with Needle 3, pick up and knit 5 (6, 7) sts along other edge of heel flap, then k3 (4, 5) heel sts again—26 (32, 38) sts total; 8 (10, 12) sts each on Needle 1 and Needle 3; 10 (12, 14) sts on Needle 2.

rnd 2: Needle 1: Knit to last 2 sts, k2tog; Needle 2: Knit; Needle 3: Ssk, knit to end—2 sts dec'd.

rnd 3: Knit.

Rep Rnds 2 and 3 until 20 (24, 28) sts rem.

foot • Cont even on 20 (24, 28) sts until piece measures about 5½ (7, 8½)" (14 [18, 21.5] cm) from back of heel, or about 1½ (2, 2½)" (3.8 [5, 6.5] cm) less than desired total length, ending at marker.

toe • Dec for tip of toe as foll:

rnd 1: Needle 1: Knit to last 2 sts, k2tog; Needle 2: Ssk, knit to last 2 sts, k2tog; Needle 3: Ssk, knit to end—4 sts dec'd.
rnd 2: Knit.

Rep Rnds 1 and 2 until 12 sts rem. Then rep Rnd 1 only (dec 4 sts every rnd) until 4 sts rem.

finish it

Break yarn, leaving an 8" (20.5-cm) tail. Thread tail on a tapestry needle, draw through rem sts twice, and pull tight to close hole. Weave in loose ends. Spritz with water and lay flat to dry. ☐

hobo bag page 46

●●○○ I'm ready to move past scarves

size it

17" (43 cm) wide and 14½" (37 cm) tall from top edge to center of bottom panel, after felting.

gather it

yarn • Classic Elite Paintbox (100% wool; 110 yd [100 m]/100 g): #6825 Fauve's palette, 4 balls. Classic Elite Montero (50% llama, 50% wool; 127 yd [116 m]/100 g): #3858 cintachi red, 1 skein. Classic Elite La Gran (76.5% mohair, 17.5% wool, 6% nylon; 90 yd [82 m]/42 g): #6546 azure, #6525 sunflower, 1 ball each.



needles • Size 13 (9 mm): straight and 24" (60 cm) circular (cir). Adjust needle size if necessary to obtain the correct gauge. **notions** • Markers (m); stitch holder or waste yarn; two 2½" (6.5-cm) brass rings; tapestry needle.

gauge it

10½ sts and 15 rows = 4" (10 cm) in St st with Paintbox, before felting; 11 sts and 18 rows = 4" (10 cm), after felting.

knit it

bag • bottom panel: With straight needles and Paintbox, CO 20 sts. Beg with a RS row, work in St st (knit RS rows; purl WS rows) for 58 rows. BO all sts.

body: With RS facing and cir needle, pick up and knit sts along bottom panel as foll: Beg at short end of panel and 1 st in from right corner, pick up and knit 18 sts along short end, turn corner, pick up and knit 34 sts along long edge (about 2 sts for every 3 rows worked in panel), turn corner, pick up and knit 18 sts along other short end, turn corner, then pick up and knit 34 sts along other long edge—104 sts total. *Next rnd*: Place marker (pm) and join for working in the rnd. K18, pm, k34, pm, k18, pm, k34. Knit 12 rnds even, slipping markers (sl m)—piece measures about 3" (7.5 cm) from pick-up. *Dec rnd*: *Sl m, k1, k2tog, knit to 3 sts before next marker, ssk (see Know It, page 55), k1; rep from * to end of rnd—96 sts rem. Rep the last 13 rnds 2 more times—80 sts rem. Cont in St st until piece measures about 14" (35.5 cm) from pick-up, removing markers on last rnd.

top, flap, and ring tabs: K12 for ring tab, slip rem 68 sts onto waste yarn or stitch holder. Turn work so that WS is facing. Work 5 rows in St st, beg with a purl row. BO 12 sts. Place next 28 sts on needle for top of bag front. Purl 2 rows. BO 28 sts purlwise. Place next 12 sts on needle for second ring tab and work 6 rows in St st. BO 12 sts. Place next 28 sts on needle for bag flap and work flap back and forth in rows as foll: **row 1**: (RS) P4, knit to last 4 sts, p4.

row 2: (WS) Purl.

Rep Rows 1–2 four more times (10 rows total), ending with a WS row. *Inc row*: (RS) P4, M1 (see Know It, page 55), knit to last 4 sts, M1, p4—2 sts inc'd. Rep the last 11 rows once—32 sts. Rep Row 2, then rep Rows 1–2 five times, ending with a WS row. Purl 5 more rows. BO all sts.

strap • With Paintbox, CO 8 sts. Work in St st until strap measures about 34" (86.5 cm) from CO. BO all sts. To attach brass ring to bag, place 12-st ring tab through brass ring and sew tab to WS of bag. Rep with rem ring tab and brass ring. To attach strap to brass ring, pull one end of strap through brass ring and sew end of strap to WS of strap, enclosing ring. Rep with the other end of strap and rem brass ring.

finish it

Weave in loose ends.

felting: Place bag in washer and set for small load and hottest water. Add a teaspoon of dish soap. Let washer agitate for 3 minutes, then check. The stitches should shrink in size but still be clearly visible. If the bag needs more agitation, cont with cycle, but check bag regularly. When the bag looks finished, remove it from the hot water, squeeze water out gently, and place in basin of sink filled with cold water. Swish gently to rinse. Gently press water from bag, roll in a towel to remove

moisture, and allow to dry flat. (Direct a fan on the piece to help it dry quickly.)

make pom-poms: With La Gran, make three 2" (5-cm) pom-poms (see Know It, page 56). With Montera, make one 3" (7.5-cm) pom-pom. Leave long tails and attach pom-poms to brass ring on right end of bag by wrapping tails around ring.

embroidery: With Montera doubled, and beg at center of bag flap 2 rows up from garter-st edge, work cross-stitches along bottom of flap and up right side edge. Turn work and work cross-st along other half of bottom edge and up left side of bag. ☐

inside-out top page 47 teva durham

●●●● I'm ready for a challenge

size it

33 (36, 39, 42, 45, 48)"
(84 [91.5, 99, 106.5, 114.5,
122] cm) bust circumference.
Sweater shown measures 36"
(91.5 cm).



gather it

yarn • Classic Elite Lush (50% angora, 50% wool; 123 yd [112 m]/50 g): #4468 madder (dark orange, MC), 9 (9, 10, 11, 12, 13) skeins; #4488 Cayman coral, #4471 fuchsia, #4415 grassland (light green), and #4450 gulf stream (light blue), 1 skein each. **needles** • Size 8 (5 mm). Adjust needle size if necessary to obtain the correct gauge. **notions** • Stitch markers (m); stitch holder; tapestry needle; binder clip for securing strands while braiding (optional).

gauge it

16 sts and 24 rows = 4" (10 cm) in reverse St st.

note it

There is a ½" (1.3-cm) garter st edging along the sides of each piece that will be used for a decorative seam allowance that shows on the right side of the finished garment. The measurements on the schematic show the actual size of the pieces, including all edgings, for checking your work. However, the edging stitches used in the seams do not count toward the finished bust size.

The left sleeve is designed so the decorative sleeve seam runs along the outside of the arm from the top point of the shoulder to the cast-on edge, instead of starting in the armpit and running down the inside of the arm in the usual manner. As a result, the lowest part of the sleeve cap is in the center of the sleeve, and the top of the cap is at each selvedge, as shown in the schematic. The right sleeve has conventional shaping.

The front shoulders are deliberately ½" (1.3 cm) wider than the back shoulders. The ½" (1.3-cm) edging along the sides of the front opening is not sewn into the shoulder seam.

Work all vertical seams with wrong sides of pieces touching. Sew seams from the right side using a mattress stitch (see

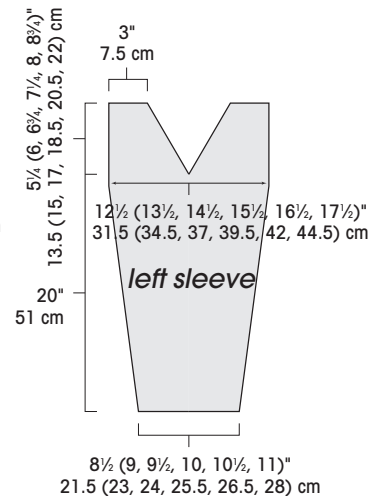
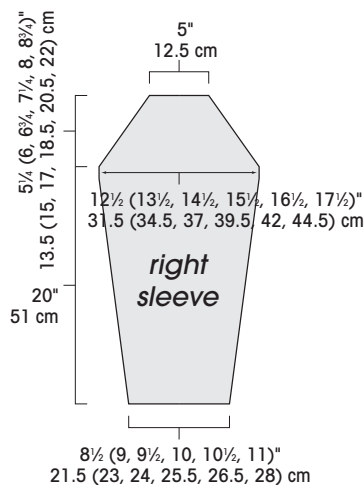
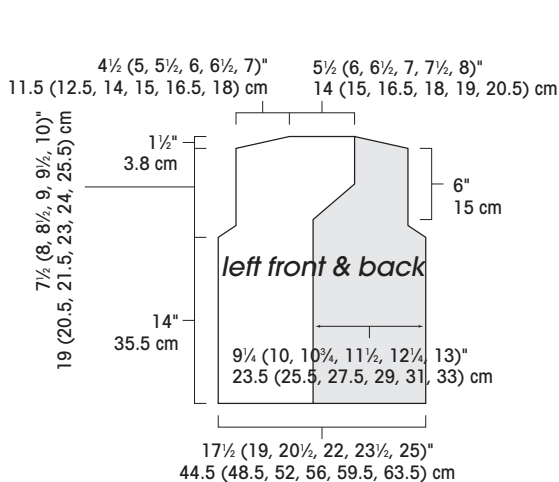

Know It, page 56), and insert tapestry needle threaded with MC into the third stitch from each edge, so that 2-stitch garter edgings will fold out to the right side. Horizontal seams should be sewn in similar manner, working into the third row from the edge so trim will fold to the right side.

knit it

back • With MC, CO 70 (76, 82, 88, 94, 100) sts. Knit 2 rows for garter st trim. *Next row:* (RS) K2, purl to last 2 sts, k2. *Next row:* (WS) Knit. Cont in established patt, working the first and last 2 sts in garter st (knit every row), and center 66 (72, 78, 84, 90, 96) sts in rev St st (purl RS rows; knit WS rows) until piece measures 14" (35.5 cm) from CO, ending with a RS row.

shape armholes: (WS) K2, ssk (see Know It, page 55), knit to last 4 sts, k2tog, k2—2 sts dec'd. *Next row:* (RS) K2, purl to last 2 sts, k2. Cont to dec 1 st each end of needle every other row in this manner 5 more times—58 (64, 70, 76, 82, 88) sts rem. Cont even as established until armholes measure 7 1/2 (8, 8 1/2, 9, 9 1/2, 10)" (19 [20.5, 21.5, 23, 24, 25.5] cm), ending with a WS row.

shape shoulders: The shoulders are shaped with short-rows (see Know It, page 56) as foll:

short-row 1: (RS) Work as established to last 8 (8, 8, 8, 10, 10) sts, wrap next st, turn work.

short-row 2: (WS) Work to last 8 (8, 8, 8, 10, 10) sts, wrap next st, turn.

short-row 3: With RS facing, work to 4 (6, 6, 8, 8, 8) sts before previous wrapped st, wrap next st, turn.

short-row 4: With WS facing, work as for Short-row 3.

short-row 5: With RS facing, work to 4 (4, 6, 6, 6, 8) sts before previous wrapped st, wrap next st, turn.

short-row 6: With WS facing, work as for Short-row 5.

short-row 7: With RS facing, work to 2 sts before previous wrapped st, wrap next st, turn.

short-row 8: With WS facing, work to 2 sts before previous wrapped st, wrap next st, turn—18 (20, 22, 24, 26, 28) shoulder sts rem unworked at each end of row.

Next row: (RS) Knit to end, working wrapped sts tog with their wraps as you come to them (see Know It, page 56). Knit 1 more row across all sts, working any rem wrapped sts tog with their wraps. BO all sts as if to knit.

left front • With MC, CO 37 (40, 43, 46, 49, 52) sts. Knit 2 rows for garter st trim. *Next row:* (RS) K2, purl to last 2 sts, k2. *Next row:* (WS) Knit. Cont in established patt, working the first and last 2 sts in garter st, and center 33 (36, 39, 42, 45, 48) sts in rev St st, until piece measures 14" (35.5 cm) from CO, ending with a RS row.

shape armhole: With WS facing, work to last 4 sts, k2tog, k2—1 st dec'd. *Next row:* (RS) K2, purl to last 2 sts, k2. Cont to dec 1 st at armhole edge (end of WS rows) every other row in this manner 3 (5, 5, 5, 5) more times—33 (34, 37, 40, 43, 46) sts rem. Work even if necessary for your size until armhole measures 1 1/2 (2, 2 1/2, 3, 3 1/2, 4)" (3.8 [5, 6.5, 7.5, 9, 10] cm), ending with a RS row. *Note:* For size 33" only, the armhole shaping is completed at the same time as the neck shaping begins; read the next section all the way through before proceeding.

shape neck: At neck edge (beg of WS rows; end of RS rows) dec 1 st every row 11 (12, 13, 14, 15, 16) times as foll: On WS rows k2, ssk, work to end; on RS rows work to last 4 sts, p2tog, k2). *At the same time*, for size 33" only, dec at armhole edge 2 more times—20 (22, 24, 26, 28, 30) sts rem after all armhole and neck shaping has been completed. Cont even as established until armhole measures 7 1/2 (8, 8 1/2, 9, 9 1/2, 10)" (19 [20.5, 21.5, 23, 24, 25.5] cm), ending with a RS row.

shape shoulder: Keeping in patt as established, work short-rows as foll:

short-row 1: With WS facing, work to last 8 (8, 8, 8, 10, 10) sts, wrap next st, turn.

short-rows 2, 4, and 6: With RS facing, work to end of row.

short-row 3: With WS facing, work to 4 (6, 6, 8, 8, 8) sts before previous wrapped st, wrap next st, turn.

short-row 5: With WS facing, work to 4 (4, 6, 6, 6, 8) sts before previous wrapped st, wrap next st, turn.

short-row 7: With WS facing, work to 4 sts before previous wrapped st (2 more than for back because front is wider at shoulders; see Note It), wrap next stitch, turn.

Next row: (RS) Knit to end, working wrapped sts tog with their wraps as you come to them. Knit 1 more row across all sts, working any rem wrapped sts tog with their wraps. BO all sts as if to knit.

right front • With MC, CO 37 (40, 43, 46, 49, 52) sts. Work as for left front until piece measures 14" (35.5 cm) from CO, ending with a RS row.

shape armhole: With WS facing, k2, ssk, knit to end—1 st dec'd. **Next row:** (RS) K2, purl to last 2 sts, k2. Cont to dec 1 st at armhole edge (beg of WS rows) every other row in this manner 3 (5, 5, 5, 5, 5) more times—33 (34, 37, 40, 43, 46) sts rem. Work even, if necessary for your size, until armhole measures 1½ (2, 2½, 3, 3½, 4)" (3.8 [5, 6.5, 7.5, 9, 10] cm), ending with a RS row. *Note:* For size 33" only, the armhole shaping is completed at the same time as the neck shaping begins; read the next section all the way through before proceeding.

shape neck: At neck edge (beg of RS rows; end of WS rows) dec 1 st every row 11 (12, 13, 14, 15, 16) times as foll: On WS rows work to last 4 sts, k2tog, k2; on RS rows k2, ssp (see Know It, page 55), work to end. *At the same time,* for size 33" only, dec at armhole edge 2 more times—20 (22, 24, 26, 28, 30) sts rem after all armhole and neck shaping has been completed. Cont even as established until armhole measures 7½ (8, 8½, 9, 9½, 10)" (19 [20.5, 21.5, 23, 24, 25.5] cm), ending with a WS row.

shape shoulder: Keeping in patt, work short-rows as foll:

short-row 1: With RS facing, work to last 8 (8, 8, 8, 10, 10) sts, wrap next st, turn.

short-rows 2, 4, and 6: With WS facing, work to end of row.

short-row 3: With RS facing, work to 4 (6, 6, 8, 8, 8) sts before previous wrapped st, wrap next st, turn.

short-row 5: With RS facing, work to 4 (4, 6, 6, 6, 8) sts before previous wrapped st, wrap next st, turn.

short-row 7: With RS facing, work to 4 sts before previous wrapped st, wrap next stitch, turn.

Next row: (WS) Knit to end, working wrapped sts tog with their wraps as you come to them. Knit 1 more row across all sts, working any rem wrapped sts tog with their wraps. BO all sts knitwise.

right sleeve • With MC, CO 34 (36, 38, 40, 42, 44) sts. Knit 2 rows for garter st trim. **Next row:** (RS) K2, purl to last 2 sts, k2. **Next row:** (WS) Knit. Cont in established patt, working the first and last 2 sts in garter st, and center 30 (32, 34, 36, 38, 40) sts in rev St st, until piece measures 2" (5 cm) from CO, ending with a WS row. **Inc row:** (RS) K2, M1 (see Know It, page 55), purl to last 2 sts, M1, k2—2 sts inc'd. Work 7 rows even as established. Working new sts into rev St st, rep the last 8 rows 7 (8, 9, 10, 11, 12) more times—50 (54, 58, 62, 66, 70) sts. Work even as established until piece measures 20" (51 cm) from CO, ending with a RS row.

shape cap: (WS) K2, ssk, knit to last 4 sts, k2tog, k2—2 sts dec'd. **Next row:** (RS) K2, purl to last 2 sts, k2. Rep the last 2 rows 14 (16, 18, 20, 22, 24) more times—20 sts rem for all sizes. Knit 2 rows for garter trim. BO all sts.

left sleeve • Work as for right sleeve until piece measures 20" (51 cm) from CO, ending with a WS row. *Note:* Because of the way the left sleeve is constructed (see Note It), the sides of the "valley" in the center of the sleeve cap correspond to the armhole edges, and the base of the valley corresponds to the base of the armhole opening. **Next row:** (RS) Work 25 (27, 29, 31, 33, 35) sts, use the backward loop method (see Know It, page 54) to CO 2 sts (for garter st trim at armhole edge), place rem 25 (27, 29, 31, 33, 35) sts on holder—27 (29, 31, 33, 35, 37) sts rem.

shape cap: The cap shaping is worked along the side of the center valley, keeping the outer selvedge straight. **Dec row:** (WS) K2, ssk, knit to end—1 st dec'd at edge of valley. **Next row:** (RS) K2, purl to last 2 sts, k2. Rep the last 2 rows 14 (16, 18, 20, 22, 24) more times—12 sts rem for all sizes. Knit 2 rows for garter trim. BO all sts. Return 25 (27, 29, 31, 33, 35) held sts to needle, and join MC ready to work a RS row. Using the backward loop method, CO 2 sts at beg of held sts, purl to last 2 sts, k2—27 (29, 31, 33, 35, 37) sts. **Dec row:** (WS) K2, knit to last 4 sts, k2tog, k2—1 st dec'd. Work 1 RS row even. Rep the last 2 rows 14 (16, 18, 20, 22, 24) more times—12 sts rem for all sizes. Knit 2 rows for garter trim. BO all sts.

finish it

See Note It for instructions on sewing seams. With MC threaded on a tapestry needle, sew center front seam, leaving 2" (5 cm) open below beg of neck shaping. Sew side and right sleeve seams. For left sleeve, sew long seam from cuff to top of cap shaping, leaving the armhole valley free. Sew shoulder seams, working 2 rows down from BO edge so garter edging will fold to RS of garment. Sew sleeves into armholes, matching base of left sleeve cap valley with base of left armhole opening. Weave in ends. Block lightly, coaxing seam allowance edgings to lie flat as shown.

blanket stitch embroidery: Cut contrasting yarns into lengths about 1½ yd (1.4 m) long for blanket stitching. Thread tapestry needle with 1 strand each of 2 different colors, using different pairs of colors on each side of the same seam as shown. Work blanket stitch embroidery over the 2-st or 2-row garter st edgings of all seams, and around the neck opening, lower edge, and cuffs, spacing the blanket sts about 2 sts or 2 rows apart.

pom-poms: Make 6 pom-poms (see Know it, page 56), using various 2-color combinations as shown.

braids: (make 2) Cut 2 strands of 2 different contrasting colors about 36" (91.5 cm) long, 2 strands 42" (106.5 cm) long, and 2 strands 48" (122 cm) long. Hold the 6 strands together, with the cut ends even at one end, and tie them together at that end with an overhand knot. Use a binder clip or other method to secure the knotted end to a notebook, table, or other sturdy surface. Keeping each pair of same-length strands held



blanket stitch

Bring threaded needle from front to back through fabric a short distance from the edge. Hold the yarn in back of the needle and pull the needle beyond the fabric edge.

together as one working end, make a simple braid. Just before each 2-strand working end runs out, use its rem few inches to attach a pom-pom on the end. Finish last strand with a pom-pom. Cut the knot off the end of the braid, thread cut ends on a tapestry needle, and starting at beg of V-neck shaping, run the needle underneath the blanket stitching along the shaped neck edge. When you reach the shoulder, pull up braid to adjust the length of the dangling pom-poms, and secure end of braid. Rep with other braid for other side of neck, with pom-poms hanging at slightly different lengths. ☐

hat & necklet page 48

doris chan

●●○○ I'm ready to move past scarves

size it

Hat—About 24" (61 cm) circumference and 6½" (16.5 cm) tall. Necklet—About ½" (1.3 cm) wide and 30" (76 cm) long.



gather it

yarn • Black Forest Naturwolle Soft (100% handspun wool; 110 yd [100 m]/100 g): #02 orange/green mix, 1 hank (used doubled). Yarn distributed by Muench Yarns. **hook** • Size N/P-15 (10 mm). Adjust hook size if necessary to obtain the correct gauge. **notions** • Tapestry needle.

gauge it

Hat—One patt rep (sc, ch 5) = about 3" (7.5 cm), measured along a straight line, with yarn doubled; Rnds 1 and 2 = about 5" (12.5 cm) in diameter. Gauge is not critical for scarf.

crochet it

hat • With yarn doubled, ch 4, sl st in beg ch to form a ring.
 rnd 1: Ch 1, 8 sc in ring, sl st in beg sc—8 sc.
 rnd 2: Ch 1, sc in same sc, [ch 5, sc in next sc] 7 times, (ch 2, dc in beg sc) for last arch—8 arches.
 rnds 3–5: Ch 1, sc in same arch, [ch 5, sc in next arch] 7 times, ch 2, dc in beg sc.
 rnd 6: Ch 1, sc in same arch, [ch 5, sc in next arch] 7 times, ch 5, sl st in beg sc.
 rnd 7: (scallop edge) [4 dc in next arch, sl st in next sc] 8 times, placing last sl st in same sc as beg. Fasten off.
 Weave in loose ends.

necklet • flower: With yarn doubled, ch 4, sl st in beg ch to form a ring.

rnd 1: Ch 1, 7 sc in ring, sl st in beg sc—7 sc.
 rnd 2: Ch 4, [sl st in next sc, ch 4] 6 times, sl st in same sc as beg—7 ch-sp petals. Do not fasten off.
 string: Ch 60. Fasten off.

ball: *5 dc in 3rd ch from hook, remove loop from hook, insert hook in top of beg ch of ball, replace dropped loop onto hook and draw through to close ball*, sl st in next 2 ch of string, ch 3, rep from * to * for second ball, sl st in each rem ch of string.

finish it

Weave in loose ends. ☐

side-way ribs page 48

Norah Gaughan

●●○○ I'm ready to move past scarves

size it

40 (44, 48)" (101.5 [112, 122] cm) worn open (fronts do not meet). Sweater shown measures 40" (101.5 cm).



gather it

yarn • Black Forest Naturwolle Tweed (100% new wool; 110 yd [100 m]/100 g): #T1-191 natural/brown mix, 6 (7, 8) skeins. Yarn distributed by Muench. **needles** • Size 13 (9 mm): 24" (60 cm) circular (cir). Spare needle (straight or cir) about the same size for three-needle bind-off. Adjust needle size if necessary to obtain the correct gauge. **notions** • Tapestry needle.

gauge it

11 sts and 16 rows = 4" (10 cm) in St st.

knit it

left half • cuff: CO 26 (26, 30) sts. Do not join, but work back and forth in rows. *Next row*: (RS) *K2, p2; rep from * to last 2 sts, k2. Cont in rib as established (knit the knits; purl the purls) until piece measures 7" (18 cm) from CO, ending with a WS row.

sleeve: (RS) Knit to last st, M1 (see Know It, page 55), k1—27 (27, 31) sts. Cont in St st (knit RS rows; purl WS rows), work 5 rows even. *Inc row*: (RS) K1, M1, knit to last st, M1, k1—2 sts inc'd. Rep the last 6 rows 4 (2, 4) more times—37 (33, 41) sts. Work 3 rows even. Rep inc row. Rep the last 4 rows 3 (7, 4) more times—45 (49, 51) sts. Cont even in St st until piece measures 20 (21, 22)" (51 [53.5, 56] cm) from CO, ending with a WS row.

front and back: With WS still facing, use the backward loop method (see Know It, page 54) to CO 45 (49, 51) sts at end

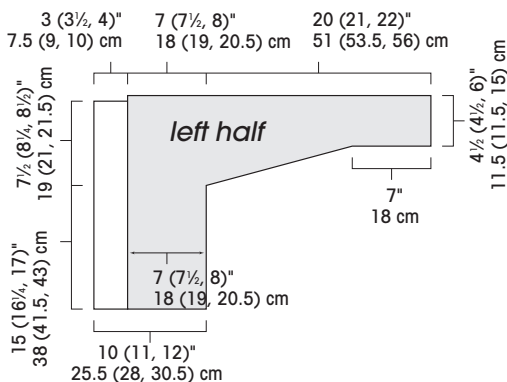

of row—90 (98, 102) sts. With RS facing (and beg with the newly CO sts), work in rib as foll: *K3, p3; rep from * to last 0 (2, 0) sts, k0 (2, 0). Use the backward loop method to CO 45 (49, 51) sts at end of row—135 (147, 153) sts. With WS facing (and beg with the newly CO sts), work in rib as foll: *P3, k3; rep from * to last 3 sts, p3. There will be 45 (49, 51) sts for the front, 45 (49, 51) sts for the sleeve, and 45 (49, 51) sts for the back. Cont even in rib as established until front and back measure 7 (7½, 8)" (18 [19, 20.5] cm), ending with a RS row.

neck: (WS) Cont in patt, BO 69 (75, 78) front sts in patt, work to end—66 (72, 75) back sts rem. Cont even in rib for 3 (3½, 4)" (7.5 [9, 10] cm) more. Place sts on spare needle.

right half • Work as for left half, but reverse shaping by binding off neck at beg of a RS row. Leave sts on needle.

finish it

Holding RS of the pieces tog, use the three-needle method (see Know It, page 54) to BO the center back sts tog. With yarn threaded on a tapestry needle, sew sleeve and side seams. Weave in loose ends. Block to measurements. ☐

pom-pom scarf page 49

kristin nicholas

●○○○ I've learned the basic stitches

size it

5" (12.5 cm) wide at center, 10¼" (26 cm) wide at ends, and 41½" (105.5 cm) long.

gather it

yarn • Classic Elite La Gran (76.5% mohair, 17.5% wool, 6% nylon; 90 yd [82 m]/42 g):

#6525 sunflower (yellow), #6585 pumpkin (orange), #6572 underappreciated green, and #6546 azure (turquoise), 1 skein each. **needles** • Size 10½ (6.5 mm). Adjust needle size if necessary to obtain the correct gauge. **notions** • Tapestry needle; pom-pom maker to make 1¼" (4.5-cm) pom-pom (available from Clover).

gauge it

12 sts and 17 rows = 4" (10 cm) in garter st.

note it

Carry the unused yarn up the selvedge edge, being careful not to pull so tight as to affect the length.

knit it

first half • With orange, CO 15 sts (counts as 1 row of stripe patt). Knit 1 row. Join green and knit 2 rows. *Knit 2 rows orange, knit 2 rows green; rep from * until a total of 25 stripes (13 orange, 12 green) have been worked—piece should measure about 12½" (31.5 cm) from CO. *Inc row 1*: Cont in patt, *k3, M1 (see Know It, page 55); rep from * 3 more times, k3—19 sts. Knit 7 rows in patt (4 stripes). *Inc row 2*: *K4, M1;

rep from * 3 more times, k3—23 sts. Knit 7 rows in patt. *Inc row 3*: *K5, M1; rep from * 3 more times, end k3—27 sts. Knit 7 rows in patt. *Inc row 4*: *K6, M1; rep from * 3 more times, k3—31 sts. Knit 14 rows in patt—piece measures about 20¾" (52.5 cm) from CO. BO all sts.

second half • With yellow, CO 15 sts. Work as first half, substituting yellow for orange and substituting turquoise for green.

finish it

With yarn threaded on a tapestry needle and RS facing, sew the CO edges of the two pieces tog. Weave in loose ends.

pom-poms: Using the 1¼" (4.5-cm) pom-pom maker (or see Know It, page 56), make 2 pom-poms of each color. With yarn threaded on a tapestry needle, sew the orange and green pom-poms alternately to the CO edge of turquoise and yellow half. Sew the turquoise and yellow pom-poms to the orange and green half. ☐

knitted dolls page 49

kathy mccart snyder

●●●○ I'm feeling pretty confident

Instructions here are for the man and woman Inuit dolls only;

on the [web](http://www.knitscene.com) knitscene.com for the other two dolls.

size it

Man—About 16" (40.5 cm) tall and 6¼" (16 cm) wide at base. Woman—About 14" (35.5 cm) tall and 7" (18 cm) wide at base.

gather it

yarn • GGH Maxima (100% merino; 121 yd [110 m]/50 g): #10 chartreuse for man and #34 old rose for woman (A), 1 ball. Muench Lucky (100% nylon; 110 yd [100 m]/50 g): #5004 gray for man and #5010 purple for woman (B), 1 ball. Muench Ferrari (79% mohair, 19% acrylic, 2% polyester; 73 yd [67 m]/50 g): #4403 gray for man and #4402 sunset for woman (C), 2 balls. Yarn distributed by Muench Yarns. **needles** • Sizes 5 and 9 (3.75 and 5.5 mm): straight. **notions** • Tapestry needle; crochet hook; wool or polyester fiberfill stuffing.

gauge it

14½ sts and 22 rows = 4" (10 cm) in garter st with Ferrari on larger needles. Exact gauge is not critical for this project.

note it

The hands and face are worked in intarsia. Join a separate length of yarn for each section, and twist the yarns at each color change, intarsia-style, to avoid leaving a hole.

knit it

feet: With A and smaller needles, CO 60 sts. Work 10 rows in St st, ending with a WS row.



legs or skirt: Change to larger needles. Join B and work 1 RS row with A and B held tog as foll: *P2, p2tog; rep from *—45 sts rem. Work 3 rows in St st, ending with a WS row. Change to single strand of C and work in garter st (knit all sts every row) for 20 rows for woman; 30 rows for man.

hands and body: Work in intarsia with A and C to create two 3-st patches for hands with A (see Note It) as foll: *Next row:* (RS) K10 with C, join new strand of A and k3, join new strand of C and k19, join new strand of A and k3, join new strand of C and k10. Work 3 rows even in colors as they appear, knitting the C sts every row for garter st, and working the A sts in St st (knit RS rows; purl WS rows). Break off A and extra strands of C. Cont with a single strand of C, knit 20 rows, ending with a WS row and inc 1 st in last row—46 sts.

face and head: Work intarsia with A and C to create a round patch with A for the face as foll:

row 1: K22 with C, join new strand of A and k2, join new strand of C and k22.

row 2: K21 with C, p4 with A, k21 with C.

row 3: K20 with C, k6 with A, k20 with C.

row 4: K19 with C, p8 with A, k19 with C.

rows 5 and 7: K18 with C, k10 with A, k18 with C.



rows 6 and 8: K18 with C, p10 with A, k18 with C.

row 9: K19 with C, k8 with A, k19 with C.

row 10: K20 with C, p6 with A, k20 with C. Break off A and second strand of C.

row 11: Cont with a single strand of C, *k5, k2tog; rep from * to last 4 sts, k4—40 sts rem.

rows 12, 14, 16, and 18: Knit.

row 13: *K4, k2tog; rep from * to last 4 sts, k4—34 sts.

row 15: *K3, k2tog; rep from * to last 4 sts, k4—28 sts.

row 17: *K1, k2tog; rep from * to last st, k1—19 sts.

row 19: *K2tog; rep from * to last st, k1—10 sts.

Cut yarn, leaving a 36" (91.5-cm) tail.

finish it

head and neck: Thread tail on a tapestry needle, draw through live sts and pull tight to close top of head. With same tail and RS facing tog, sew center back seam to top of feet. With CO tail of A, sew center back seam of feet, working from CO edge upward. Inserting stuffing from opening at CO edge, stuff head end of doll with wool or fiberfill. Thread a 24" (60-cm) length of C on a tapestry needle, and beg at center back seam, run this strand around the neck about 2 garter ridges below beg of face, weaving the strand over one st, under one st. Gather ends of the strand like a drawstring, pull up snugly to form neck, and tie in a double knot to secure. Take ends of knot to inside. Weave in ends.

body: Stuff rest of body. Flatten doll slightly with the face in the middle and one hand at each side. With A, sew the bottom opening closed.

arms: With C and beg just below the hand patch, sew a 3½" (9-cm) line to define each arm, beg about ½" (1.3 cm) in from side at first row of hand, and angling slightly inward so that line is about 1" (2.5 cm) in from side at armpit; arm will be thicker at the top than at the end of the fingers.

legs: (man only) With C and beg at center of lower edge, sew a line through all layers about 8" (20.5 cm) up from CO edge to define legs.

fringe: Cut 4" (10-cm) lengths of B for fringe. Attach individual strands all the way around top of feet at junction between A and C, and around face as foll: Fold one strand in half, use crochet hook to pull loop through at desired location, pull ends of yarn through loop and tighten. □

Many, many thanks to the businesses **Black Parrot**, **Josephine**, **Eclectic Closet**, and **All Small Antiques** for their help in styling the sweaters in this issue. For information on the garments and accessories pictured, contact:

Black Parrot, 328 Main St., Rockland, ME 04841; (207) 594-1961; www.blackparrotonline.com.

Josephine, 39 Mechanic St., Camden, ME 04843; (207) 236-2123; www.ejosephine.com.

Eclectic Closet, 96 Main St., Belfast ME 04915; (207) 338-0451.

All Small Antiques, RR 1, Searsport, ME 04974; (207) 338-1613.

Rosies Yarn Cellar

We carry Classic Elite's "Lush"
and the complete color range of
La Gran Mohair and Inca Alpaca

www.rosiesyarncellar.com
or call (215) 977-9276 • Philadelphia, PA

Knitting Yarn Store
Finest Quality Sari Silk Yarn & Fibers



...priced well below retail!
knitting-yarn-store.com
415.354.1785

Wild & Woolly

Specialty yarns
and accessories.
Everything for the
discriminating
fiber craftsperson.



ON THE GREEN

7A Meriam St.
Lexington Center, MA 02420
781.861.7717
E-mail: woolly@aol.com

The Fibre Company
unique artisan yarns

Discover our luxurious
natural fiber yarns

Fauna - *animal origins*
Khroma - *lit by the sun*
Terra - *natural inspiration*



www.TheFibreCo.com

**Crocheted Felt
Ballet Slippers**
from *Fiber Trends*

Kit Special
\$19.95 + s&h
pattern & 10 ply Wool
in berry, red, navy, med blue,
olive, or brown.



Acorn Street Shop

order line 1.800.987.6354
2818 NE 55th St. Seattle, WA 98105
(206) 525-1726 • www.acornstreet.com

**DREAM
weaver
yarns**
.com™

10% OFF YOUR NEXT ORDER
Enter Discount Code **KSC5** at checkout!
(Specials and Gift Certificates not included.)

string
for luxury knitting



purchase online
www.stringyarns.com

visit us
1015 madison avenue
new york city

order by phone
212.288.yarn

Jordana Paige
THE KNITTER'S MESSENGER BAG



**Pockets for
your project,
knitting tools,
pattern and
daily items.**

Available in
Camel/Brown &
Navy Blue/Black
15w x 11.5h x 6d in.

WWW.JORDANAPAIGE.COM (408) 439-3756

Dancing Leaf Farm

*Color Splashed Yarn
Painted on the Farm*



301-801-6995
Barnesville, Maryland
www.DancingLeafFarm.com



*One-of-a-kind
Fused Glass Buttons*

www.perfectbuttons.com
505.286.1783

Ashland Sky Knit Stick Sacks

New for crochet



A Portion of the profits from the Pink Sacks goes to WinABC

For wholesale information: 541.482.3390
For a retailer near you visit: www.ashlandsky.com



Colorful Alpaca Yarns!

www.GenesisAlpacas.com
360-659-1990



MOCO YARNS QIVIUT

The world's most exceptional rare fiber!

www.CaryllDesigns.com
Box 30, Tendency, ID 83468
Phone: (208)756-4702 Fax: (208)756-4732
Natural, 8 Dyed Solids, 4 Mountain Colors



Seattle Knitting Expo

April 28, 29, 30 2006

Marriott Hotel
Sea/Tac Airport
Merchant Market, Fashion Shows,
Nationally known Instructors,
Hand & Machine Knitting,
Crocheting Classes, and Wearable Art

Call: Arlene Vraney 360-805-4847
avraney@verizon.net
www.seattleknittingexpo.com

Vintage Yarns

KNITTING WITH A NEW TWIST

3478 W. STERNS ROAD • LAMBERTVILLE, MI 48144
734.854.KNIT (5648) • vintageyarns@buckeye-express.com
www.vintageyarns.com

Circular Needle ID Tags™

They snap onto your cable and they contain both US & metric sizes!



nancysknitknacks.com See your LYS

A new system for marking your circular needles so that you can easily identify their size.

Nancy's Knit Knacks 800-731-5648

LA PETITE Knitterie

For The Knitting Artisan

Natural Fibers,
Hand Spun & Hand Painted Yarns

Open Tuesday - Friday from 10 - 6 pm
Saturday from 10 - 4 pm
Sunday from 11 - 4 pm • Closed Monday

25642 Crown Valley Parkway, Suite E3
Ladera Ranch, CA 92694 • 949.347.7973



GREEN MOUNTAIN SPINNERY

Natural fiber yarns at their luxurious best...

800.321.9665 · www.spinnery.com
PO Box 568 · Putney, Vermont 05346

<http://stores.ebay.co.uk/colourmartuk>

DESIGNER CASHMERE

REMAINDER PRICES

WORLDWIDE SERVICE

<http://stores.ebay.co.uk/colourmartuk>

Vintage Knits Wool Shoppe

“supplier of exquisite knitting fibers”

Order Online
www.vintageknits.net

Vintage Knits Wool Shoppe LLC

Elissa's
Creative Warehouse

Knitting • Needlepoint
Crochet
Classes Available

Phone: (781) 444-9341 Riverbend Office Park
Fax: (781) 449-6322 220 Reservoir Street
www.elissascreativewarehouse.com
Needham Heights, MA 02494
Hours: 10-4:30, Sun. 12-4, Closed Wed.,
Closed Sun. Spring - Summer

Welcome to Babes' World!

Knitted Babes

Five Dolls & their Wardrobes to Knit & Stitch

Claire Garland

You won't be able to resist these knitted “retro rag dolls” or making them and all their easy, fabulous handknit and handsewn trendy clothes, like hats, purses, skirts, flare pants, hoodies, stoles, tutus, slippers, and dresses.

\$19.95, paperbound, 8 x 10, 128 pages
ISBN 1-59668-000-8

Unlimited fun at
www.knittedbabes.com
Check it out!

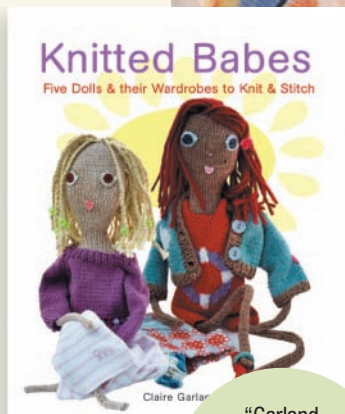

“Garland revolutionizes the entire notion of knitted dolls.”
—*Knitter's Review*

 **INTERWEAVE PRESS**
www.interweave.com

201 East Fourth Street • Loveland, Colorado 80537-5655
Shipping is \$4.95 for the first book, \$1.00 for each additional book
(800) 272-2193

Alaska

The Net Loft—Cordova

Beautiful yarns, needlework, lovely ribbons, and unique buttons, papercrafts, jewelry, fine chocolates, and friends.

140 Adams St., (907) 424-7337

California

Needle in a Haystack—Montrose

Everything for the needle worker. Great selection of knitting yarns, needlepoint, and cross stitch supplies.

2262 Honolulu Ave., (818) 248-7686

Simply Knitting—Santa Clarita

SCV's finest for luxury yarns, accessories, patterns, books, classes, and more. Personal and knowledgeable service in a relaxing shopping environment.

22913-1/2 Soledad Canyon Road, (661) 259-6864

Skein Lane—El Cerrito

Inspiring selection of yarns, needles, and accessories for knitters, crocheters, and needle workers. Visit us in the shop or at www.skeinlane.com.

7512 Fairmount Ave., (510) 525-YARN

West Valley Alpacas—Esparto

Ah, ALPACA! Alpaca yarn, kits, needles, patterns, classes, ranch tours, and more! By appointment. www.westvalleyalpacas.com.

19190 Road 87B, (530) 662-8630

Colorado

Coppelia's Needlepoint & The Shivering Sheep—Denver

Established 1993. Specializing in hand-painted needlepoint canvas. Custom designed knitting patterns. Contemporary knitting yarns and unique yarns from Colorado's llamas and alpacas. Plus a large selection of books to choose from!

231 Milwaukie St. Cherry Creek-North, (303) 320-7776

Table Rock Llamas Fiber Arts Studio, Inc.—Colorado Springs

Spinning, weaving, felting, dyeing, knitting, and crocheting. Owners of The DyeWorks natural dyes, mordants. Assists. www.tablerockllamas.com.

6520 Shoup Road, (719) 495-7747

The Indigo Thread—Fort Collins

Spinning, knitting, and weaving supplies, equipment, fibers, yarns, dyes, and workshops. Quality, selection, excellent prices.

3307 S. College Ave. #9, (970) 225-8001

Woolen Treasures Yarn Shop—Loveland

Cherry Tree Hill, Interlacements, Blue Sky Alpacas. Home-made buttons. Classes available. Located just 3 blocks east of Interweave Press! www.woolentreasures.com.

527 E. 4th St., (970) 613-0556

Florida

All Strung Out—Cocoa Beach

Beads, baubles, buttons, yarns, fibers—exceptionally exquisite, inspirational items. Great ideas—free instruction.

46 N. Brevard Ave., (321) 783-4550

Georgia

Nease's Needlework—Decatur

We specialize in friendly, personal service and natural fiber yarns. Classes available! www.neasesneedlework.com.

335 West Ponce de Leon Ave. Ste. G, (404) 377-6875

wild fibre—Savannah

Artist owned and operated. Creative, unique, local hand dyed, handspun, natural, and novelty yarns.

409 East Liberty St., (912) 238-0514

Illinois

Mosaic Yarn Studio, Ltd—Des Plaines

Helpful, knowledgeable staff; unique patterns and yarns, Addi Turbo Needles, workshops, special events, classes. www.mosaicyarnstudio.com.

1585 Ellinwood St., (847) 390-1013

Yarn Sellar—Loves Park

We stock fine yarns from Berroco, Trendsetter, Dale of Norway, Tahki, and more!

6128 E. Riverside Blvd., (815) 637-9666

Kentucky

Koenig Farm, Spinnery & Yarn Shop—Springfield

Luxurious 100% mohair yarns and rovings; natural and hand painted. Spinning mill tours available. www.koenigfarm.com.

2811 Beechland Rd., (859) 336-8438

Maine

Halcyon Yarn—Bath

One stop shopping for all your knitting needs: yarn, needles, notions, books, etc. service@halcyonyarn.com, www.halcyonyarn.net.

12 School Street, (800) 341-0282

Naturally Fuzzy Yarns—Harrison

We've got the good stuff! A knitter's paradise of quality yarns, books, patterns, and accessories.

24 Zakelo Rd., (207) 583-2654

Maryland

Yarns International—Bethesda

We are a full service shop near Washington, DC. Originator of Shetland 2000® pure undyed Shetland yarn.

5110 Ridgefield Rd., Suite 200, (800) 927-6728

Massachusetts

Adventures in Knitting—Harwich Port

Cape Cod's oldest yarn shop, has the newest yarns, designs, and a passion for knitting! cham-matt@comcast.net; www.adventuresinknitting.com.

554 Main St., (508) 432-3700, (508) 432-7867

Creative Warehouse—Needham

We could list everything we have, but there's not enough space. Find out why knitters from all over New England make the trip to Creative Warehouse. www.elissascreativewarehouse.com.

220 Reservoir Street, (781) 444-9341

Newbury Yarns—Boston

Boston's best kept secret specializing in luxury fibers, knitting accessories, workshop, and classes. www.newburyyarns.com.

164 Newbury Street, (617) 572-3733

Sheep to Shore—Nantucket

A complete knitting shop on Nantucket Island offering the finest yarns and supplies available.

14 Sparks Avenue, (508) 228-0038

The Fiber Loft—Harvard

Knitting—Weaving—Spinning. Serving fiber enthusiasts for over 30 years. We have what you need! www.TheFiberLoft.com.

9 Massachusetts Ave. (Rte 111), (978) 456-8669

Webs—Northampton

Your source for the finest in weaving, spinning, and knitting supplies. Visit us at www.yarn.com.

75 Service Center Road, (800) 367-9327

YARNS in the Farms—Beverly Farms now open

Luscious yarns, books, buttons, bags. Located in antique candy shop in seaside village. Lively classes.

641 Hale Street, (978) 927-2108

Michigan

Busy Hands—Ann Arbor

"Life is too short to knit with boring yarn." Artful Yarns, Reynolds, Vittadini, and Kertzer. Classes. Specializing in exceptional customer service!

306 S. Main St. Suite 1-C, (734) 996-8020

City Knits—Detroit

THE BEST PLACE FOR YARN IN DETROIT! Color nirvana-gourmet fibers. Buttons/needles/books/classes. Fisher Building. www.cityknits.com.

3011 W. Grand Blvd., Suite C-9, (313) 872-9665

Knit Knit Knit—West Bloomfield

We are a full-service shop, carrying a spectacular line of yarns and canvasses. Orchard Mall. www.knitknitknit.com.

6369 Orchard Lake Rd., (800) 860-KNIT (248) 855-2114

Minnesota

Silver Creek Cabin—Buffalo

For those on a "fiber diet", you should be able to find something to satisfy your cravings. Also unique gift items and Basketville baskets. www.silvercreekcabin.com.

6 Division Lower Level, (763) 684-0554

New Hampshire

Hodge Podge—Newport

Large selection of commercial yarns, books, and needles; also carry spinning wheels and fibers.

59 Belknap Ave., (603) 863-1470

New Mexico

Miriam's Well—Santa Fe

Santa Fe's premier yarn shop. Local, national, and international designer yarns. www.sfschoolofweaving.com.

614 Paseo de Peralta, (505) 982-6312

New York

Knit-A-Way—Brooklyn

Offering classes, private lessons, fine yarns, hooks, needles, notions, books, patterns for your knitting/crocheting needs. www.knitaway.com.

398 Atlantic Avenue, (718) 797-3305

Seaport Yarn—New York City (Wall St. area)

Wide selection of yarns, needles, patterns, and gadgets at great prices. Classes available.

135 William St. 5th Fl., (800) 347-2662

Stitch Therapy—Park Slope, Brooklyn

...a luxurious oasis of rich colors and fibers for knitters and crocheters. www.stitchtherapy.parkslope.com for class schedule and private lessons also available.

176 Lincoln Place, (718) 398-2020

North Carolina

The Tail Spinner—Richlands

Complete fiberarts center: Quality yarns, spinning wheels, looms, classes, related tools, and equipment. Visit www.tail-spinner.com.

109 North Wilmington St., (910) 324-6166

Oregon

All About Yarn—Tigard

Meeting your knitting needs and serving your creative expectations one strand at a time. Visit us at: www.allabout yarn.net.

11945 SW Pacific Hwy. Suite 111,
(503) 684-4851

Knitting Bee—Portland Westside

Inspiring yarn and notions for knitting and crochet. Located 15 minutes west of Portland just off Hwy 26.

18305 NW West Union Rd., (503) 439-3316

Knot Another Hat—Hood River *now open*

Your source for everything hip and knitworthy! Find fine yarns, needles, accessories, gifts, and more! www.knotanotherhat.com.

16 Oak Street, Suite 202, (541) 308-0002

The Knit Shop—Eugene

Full selection of yarns, needles, patterns, and accessories. Visit our website! www.knit-shop.com; jean@knit-shop.com.

2821 Oak Street, (541) 434-0430

Pennsylvania

Knitter's Underground—Centre Hall

Complete knitting, weaving, spinning, and needlepoint supplies. Appleton, Shetlands, Joeger, Brittany, Schacht, and much more! www.knitters-underground.com.

308 S. Pennsylvania Avenue, (814) 364-1433

Texas

Yarns 2 Ewe, Inc.—Houston

New, larger location! Large selections of yarn, needles, accessories and books, and friendly customer service. www.yarns2ewe.com.

518 Shepherd, (713) 880-KNIT (5648)

Utah

Piper's Quilts & Comforts—Salt Lake City

Fine fabrics and fine yarns! Tahki, Rowan, Muench, Skacel and much more! Online shopping available. www.pipersquilts.com.

1944 South 1100 East, (801) 484-5890

Washington

Parkside Wool Company, Inc.—Bellevue

A classic local yarn shop. Specializing in knitting, needlepoint, crochet, spinning, felting, and friendly, professional customer service. www.parksidewool.com.

17 102 Ave. N.E., (425) 455-2138

Wisconsin

Artistic Fibers—Burlington

Contemporary shop offering quality yarn, patterns, accessories, and a supportive environment for your creative side.

324 N. Pine Street, (262) 757-0960

Bahr Creek Llamas & Fiber Shop—Cedar Grove

Wide variety of yarns and roving for the fiber artist. Adi Turbo/Crystal Palace bamboo needles. www.bahrcreek.com.

N. 1021 Sauk Trail, (920) 668-6417

Loop Yarn Shop—Milwaukee

Loop supports all knitters and crocheters in their creative fiber endeavors and aspirations! www.loopyarnshop.com.

2900 S. Delaware Ave, (414) 481-4843

The Dragonfly Yarn Shop—Janesville

Cascade, Louet, Knit One Crochet Too, Skacel, Addi Turbo, Crystal Palace. Catch the knitting spirit!

1327 N. Wright Rd. Suite 5A, (608) 757-9228

England

ColourMart—Shrewsbury

eBay shop, huge range remainder CASHMERE designer yarns from top Scottish mills. Superb service worldwide. www.stores.ebay.co.uk/ColourMartUK.

59 New Street, +44 (0) 1743 365097

fibers

Alpaca! Natural and dyed knitting yarns, kits. **West Valley Alpacas**, 19190 Road 87B; Esparto, CA 95627. (530) 662-8630; www.westvalleyalpacas.com.

literature

Huge selection new and out-of-print knitting and other needlework books. Free catalogs and newsletter: **Ruth Kern Books**, PO Box 35366, Phoenix, AZ 85069. Free book searches. (800) 429-5075; fax (602) 944-1753; rkern3@mindspring.com; www.needlearts.com.

patterns

Heirloom Knitted Lace, your source for beautiful lace patterns. www.Knitlacepatterns.com or Knlace@Ktis.net.

travel

Join **Nicky Epstein** for knitting and felting workshops on our 7th annual Shetland Isles Knitting Escape. July 2006. Complete details at www.simplyshetland.net.

PUCHKA Perú Textiles/Folk Art/Market Tours. Twenty-two days in enchanting Perú featuring intensive hands-on workshops with Indigenous knitters, weavers, spinners, embroiderers, braiders, and gourd engravers. Includes Machu Picchu, Museums, Markets, and More..... www.puchkaperu.com, textiletours@puchkaperu.com.

UK and Ireland Fiber, Textile, and Craft Tours. August 2006, Festival of Quilts and Jen Jones Welsh Quilts. October 2006, Circle Ireland including Knitting and Stitching Show, Dublin. **Handcraft-**

Holidays, www.handcraftedholidays.com, handcraftedholidays@yahoo.com.

Personalized letters from Santa only \$3.50. We accept checks and credit cards. Check us out at www.givinggiftsthatgive.com.

yarns

Chasing Rainbows Dyeworks hand-painted yarns and fibers. Matching solids available. Wholesale inquiries welcome. 1700 Hilltop Dr., Willits, CA 95490; (707) 459-8558; fax (707) 459-6417. Wool, mohair, silk blends.

Hand-Painted Yarns. Create a garment like no other from unique, hand-painted yarns dyed in small batches. No two yarns alike. **Spirit Trail Fiberworks**; www.spirit-trail.net, info@spirit-trail.net. (703) 309-3199.



Acorn St. Shop	107
Anneke's Needlework	67
Ashland Sky	108
Brittany Company	6, 75
Coryll Designs	108
Chris Bylsma Designs	65
Classic Elite Yarns	bc
Colorful Stitches	73
ColourMart	109
Creative Impressions in Clay	6
Creative Warehouse	109
Dancing Leaf Farm	108
Dovetail Designs	6
Dream Weaver Yarns LLC	6, 107
Elann.com Inc.	71
Fiber Trends/Bryson Distributing	67
Fibre Company, The	107
French Girl	61
Genesis Alpacas	6, 108
Green Mountain Spinnery	109
Halcyon Yarn	6
Interweave Press	6, 71, 109
JConklinDesigns	6

Jordana Paige	107
K.M. Productions	108
Kaleidoscope Yarns	69
Knit and Stitch=Bliss	6, 73
Knit Happens	75
Knit Pixie	6
KnitNet	6
Knitting Central	65
Knitting Room, The	6
Knitting-yarn-store.com	107
La Petite Knitterie	108
Louet Sales	6, 61
Martingale & Co.	77
Muench Yarns Inc.	5, 6, 36-37
Nancy's Knit Knacks	108
Paradise Fibers	71
Passing Paws Press	63
Perfect Buttons	108
Purl	59
Purlis the Yarn Studio	73
Rosie's Yarn Cellar	107
Royal Yarns	6
Russi Sales	6, 61

Skacel Collection, Inc.	6
Spirit Work knitting & designs, Inc	6
Stitch DC	67
Stitch Therapy/A Fine Yarn Shop	6
String	107
Suss Design	69
Tahki Stacy Charles	6, 7, 41
Talitha Cumi Co.	6
Tricoter	63
Unique Kolours	6, 51
Vintage Knits Wool Shoppe LLP	109
Vintage Yarns Knitting with a New Twist	108
Web'stars	63
Webs	69
West Valley Alpacas	6
Wild and Woolly Studio	107
Woodland Woolworks	6
Wool 2 Dye 4	6
Yarn Company, The	75
Yarnmarket, Inc	65

No 2 September–February · www.rebecca-online.com

USA \$ 16,95 | Great Britain £ 8,99 | Germany 8,80 €



Rebecca

special

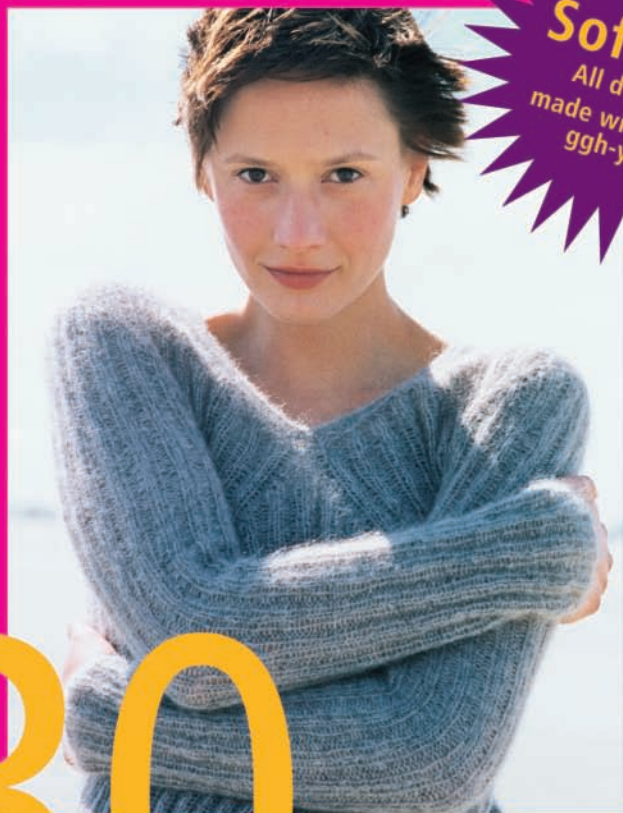

Soft Kid

All designs
made with fluffy
ggh-yarn

30 cuddly
Super Kid Mohair
designs

Rebecca



“Look at me!”

For a Retailer near you email us at: rebecca@muenchyarns.com
The new Rebecca, Knitwear designs easier than ever!

Classic Elite Yarns

Fall '05 – It's all about luxury.

Cashmere, angora, extra fine merino – a fabulous blend of fibers with a cashmere-like hand, and with just a hint of angora “bloom”.

We've developed this yarn in two weights – to combine and compliment – to layer and wrap.

Princess, 5 sts/in, perfect to layer with itself, and with

Duchess, 3½ sts/in. Both yarns are available in the same twenty-one luxurious colors.

Find these three garments in our “**First Edition**” Booklet.

To mail-order this Booklet send \$12.95 to:

Classic Elite Yarns

Dept. KSF05

122 Western Avenue

Lowell, MA 01851

Visit our website,
www.classiceliteyarns.com

for images of all garments in all Booklets,
all yarns in all colors,
and to find a retailer in your area.

